



# Orinda Union School District

8 Altarinda Rd, Orinda, CA 94563



**SWINERTON**  
MANAGEMENT & CONSULTING

ADDENDUM NO. 01

March 12, 2026

TO : All Bidders  
FROM : Orinda Union School District ("District")  
PROJECT : Glorietta Elementary School Transitional Kinder/Kindergarten Play Yard  
SUBJECT : **Addendum No. 01 ("Addendum")**

The following changes, omissions, and/or additions to the Contract Documents shall apply to all submissions, and all other conditions shall remain the same.

Careful note of the Addendum shall be taken by all parties of interest so that the proper allowances may be made in strict accordance with the Addendum, and that all trades shall be fully advised in the performance of the Work which will be required of them. It is the obligation of the General Contractor to make all subcontractors aware of any items herein.

**Acknowledge receipt of this Addendum by inserting its number and date in the Bid Form. Failure to do so may subject bidders to disqualification.**

## I. PRE-BID RFIS

1. **QUESTION:** Please provide Engineer's Estimate.

**RESPONSE:** \$ 768,923

Note: The Engineer's Estimate represents the total cost of the Base Bid together with all four (4) Additive Alternates

2. **QUESTION:** Do you have to prequalify? If so, Can you direct me to where to access the documents?

**RESPONSE:** Contractor shall possess at the time of Bid, valid Type B, Contractor's license(s) issued by the State of California, Contractor's State Licensing Board, in accordance with division 3, chapter 9, of the Business and Professions Code and in the classification called for in the Bid Documents.

3. **QUESTION:** Is there a project labor agreement?

**RESPONSE:** There is not a project labor agreement.

## II. SUBSTITUTION REQUEST

None

## III. CHANGES TO SPECIFICATIONS

None



# Orinda Union School District

8 Altarinda Rd, Orinda, CA 94563



**SWINERTON**  
MANAGEMENT & CONSULTING

## **IV. CHANGES TO DRAWINGS**

**None**

## **V. ADDITIONAL INFORMATION**

Additional details related to the two (2) Owner-Furnished, Contractor-Installed (OFCI) play equipment items are included as exhibits with this addendum.

### 1. Exhibit-A

Manufacturers Shop Drawings of two OFCI play equipment -

- i. Play Structure "Little Fix Shop" -Kompan Product number NRO936393
- ii. Play Structure "Robinia Tower with Slide"-Kompan Product Number NRO936417

### 2. Exhibit-B

- i. Installation and footing details of Play Structure "Little Fix Shop" -Kompan Product number NRO936393
- ii. Installation and footing details of Play Structure "Robinia Tower with Slide"-Kompan Product Number NRO936417

**EXHIBIT-A**  
**ADDENDUM\_01**

# Glorietta ES

Play Equipment

15 Martha Rd, Orinda CA 94563



Lorne Smith  
Market Development Leader | Northern California  
510 277 5691  
lorsmi@kompan.com

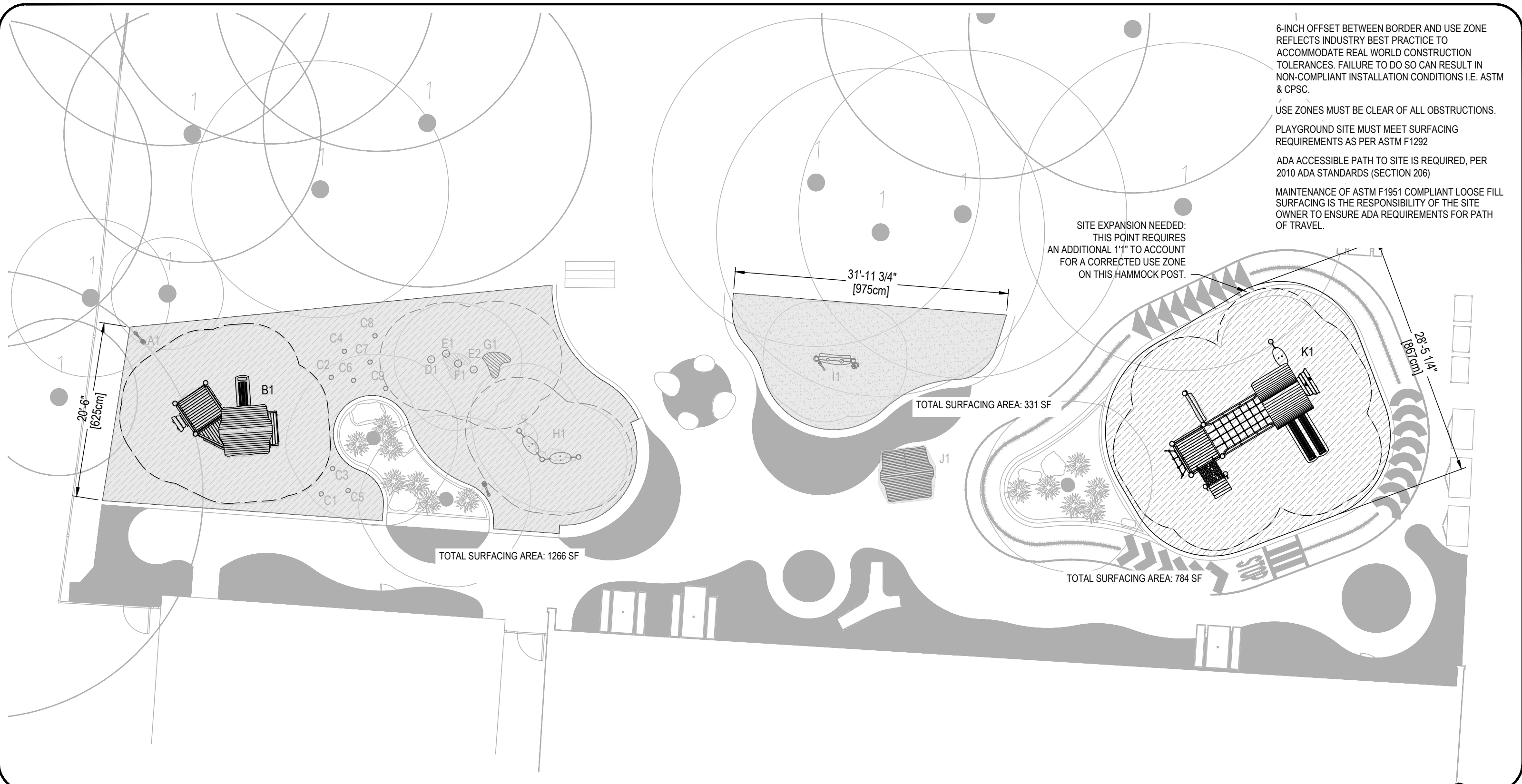

#	Product Number	Product Name	M.F.H.	Count
A	PCMP714557	Talk Tube	0'0"	1
B	NRO936393	Little Fox Shop	1'11"	1
C	NRO209-xx01	Sitting Pole	0'0"	9
D	NRO932890	Stump	0'8"	1
E	NRO932889	Stump	1'0"	2
F	NRO932888	Stump	1'6"	1
G	NRO104-xx02	Spring Board	1'6"	1
H	NRO931286	Robinia Hammock	2'4"	1
I	NRO510-0601	Sand Desk	0'0"	1
J	NRO40401-0611	Village Shop	0'0"	1
K	NRO936417	Robinia Tower With Slide	2'10"	1

## Glorietta Elementary School

15 Martha Road  
Orinda, CA 94563  
Site Plan - Ages 2-5



MANUFACTURER'S SHOP DRAWING:

FOR USE BY CONTRACTOR, ENGINEER, OR DESIGN PROFESSIONAL OF RECORD. SEE SIGNED SALES PROPOSAL FOR COMPLETE SCOPE TO BE PROVIDED BY KOMPAN OR REPRESENTING AGENCY. CONFIRM FINAL PLAN AND SCOPE WITH KOMPAN SALES REP OR PROJECT MANAGER PRIOR TO USE FOR REVIEW, PERMITTING, OR CONSTRUCTION.

TO BE READ CONTINGENTLY WITH KOMPAN'S STANDARDS FOR SITE PREPARATION, MATERIALS AND INSTALLATION PROCESSES. PROVIDED AFTER EQUIPMENT PURCHASE. A COMPLIANT PLAYGROUND TO KOMPAN'S STANDARDS MUST SATISFY ALL REQUIREMENTS IN THE CODE OF CONDUCT.

SLAB BY OTHERS UNLESS OTHERWISE NOTED. FOR SURFACE MOUNT OPTIONS, THE CONCRETE REQUIREMENTS MAY BE UP TO 5\"/>

DIMENSIONS OF PLAY AREA, SIZE AND ORIENTATION, LOCATIONS OF ALL EXISTING UTILITIES, EQUIPMENT AND SITE FURNISHINGS TO BE FIELD VERIFIED PRIOR TO CONSTRUCTION.

PREPARED AND PRINTED IN USA BY KOMPAN © 2025 KOMPAN, INC. AUSTIN, TX. USA 800-426-9788

6-INCH OFFSET BETWEEN BORDER AND USE ZONE REFLECTS INDUSTRY BEST PRACTICE TO ACCOMMODATE REAL WORLD CONSTRUCTION TOLERANCES. FAILURE TO DO SO CAN RESULT IN NON-COMPLIANT INSTALLATION CONDITIONS I.E. ASTM & CPSC.

USE ZONES MUST BE CLEAR OF ALL OBSTRUCTIONS.

PLAYGROUND SITE MUST MEET SURFACING REQUIREMENTS AS PER ASTM F1292

ADA ACCESSIBLE PATH TO SITE IS REQUIRED, PER 2010 ADA STANDARDS (SECTION 206)

MAINTENANCE OF ASTM F1951 COMPLIANT LOOSE FILL SURFACING IS THE RESPONSIBILITY OF THE SITE OWNER TO ENSURE ADA REQUIREMENTS FOR PATH OF TRAVEL.



SALES REPRESENTATIVE			SHEET
LorSmi			K1.0
REVIEW BY DESIGN	DRAWN BY JoaAce	DATE 09/18/25	
REV. NO. 6	REV. BY SuzWys	REV. DATE 11/25/25	REVISION NOTES Equipment

LAYOUT IS IN ACCORDANCE WITH ASTM F1487

Binding approval for Variant Design

When pressing "Prepare to order" in CRM all purchases are subject to this design. This design is defined under its own KOMPAN identification number, which is stated in upper right corner. All constructional details, dimensions, materials, colours and specifications shown on attached datasheets (plan, side, perspective view + safety zone) are hereby accepted when placing the order. Changes are no longer possible.

Notwithstanding the aforementioned and without changing the overall design, Variant Team may in the construction phase, without obtaining approval, perform smaller modifications when deemed beneficial or necessary for the construction. All other modifications are subject to prior approval.

PLAY STRUCTURE: LITTLE FOX SHOP

NRO-CUSTOM

936393

Identical w/: NRO418-1021  
Footings: WOOD 100 cm  
Color: Colored version  
Comments: Colored parts Blue -0030



Designer MatCha  
Created 20.11.2025

#### Binding approval for Variant Design

When pressing "Prepare to order" in CRM all purchases are subject to this design. This design is defined under its own KOMPAN identification number, which is stated in upper right corner. All constructional details, dimensions, materials, colours and specifications shown on attached datasheets (plan, side, perspective view + safety zone) are hereby accepted when placing the order. Changes are no longer possible.

Notwithstanding the aforementioned and without changing the overall design, Variant Team may in the construction phase, without obtaining approval, perform smaller modifications when deemed beneficial or necessary for the construction. All other modifications are subject to prior approval.



## PLAY STRUCTURE: ROBINIA TOWER WITH SLIDE

NRO-CUSTOM

936417

Variant of:	NRO409
Footings:	WOOD 100 cm
Color:	Colored version
Comments	Colored parts Blue-0030. Rope Bridge Orange

Designer TomVag  
Created 25.11.2025

NRO-CUSTOM

936417



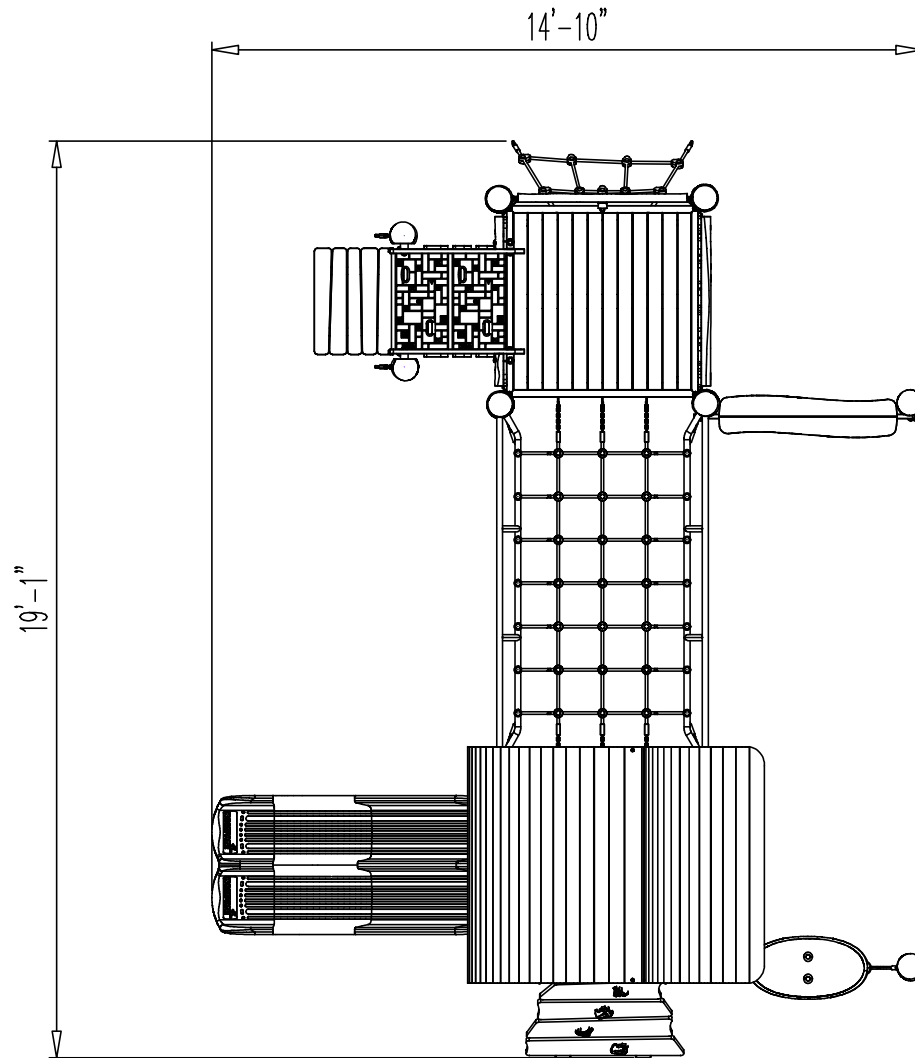

NRO-CUSTOM

936417

1:1/4"

# ASTM F1487

NRO-CUSTOM

## 936417

1:1/8"

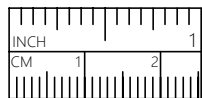
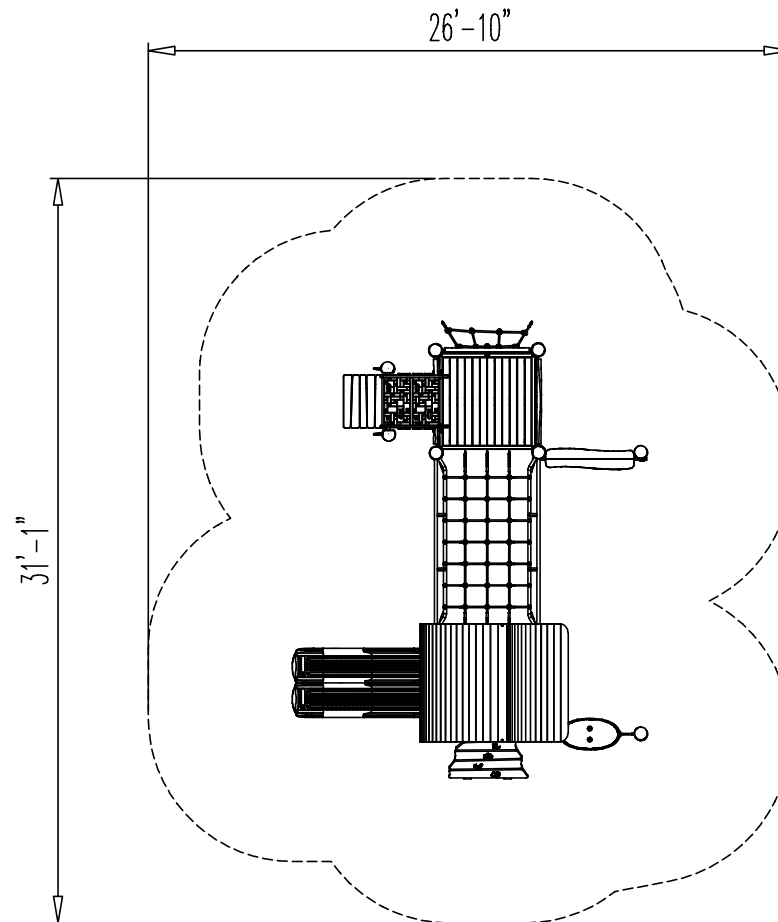

ASTM F1487

NRO-CUSTOM

936417

1:1/4"

\*\*12'-6"

\*3'-3"

0"

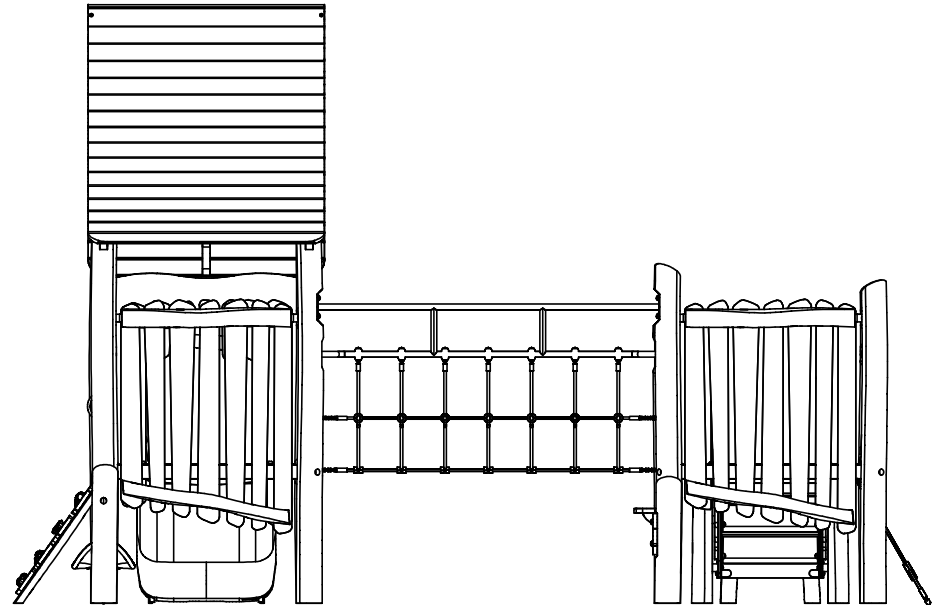
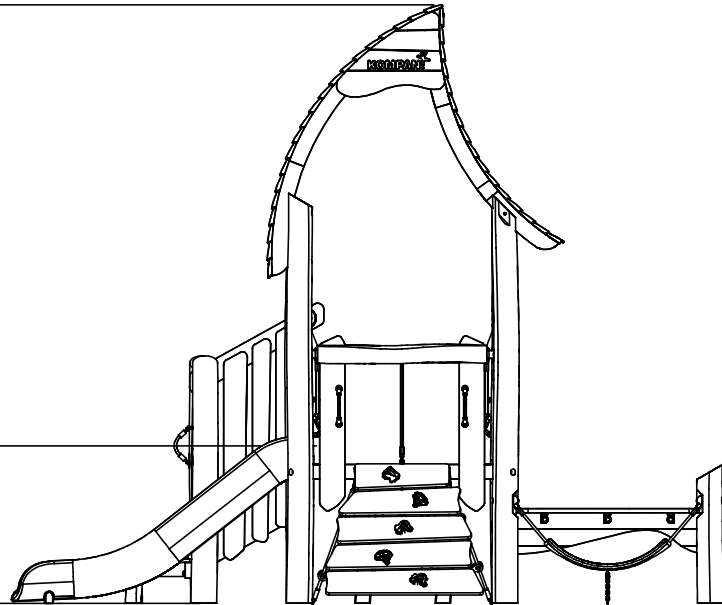

# WARRANTY

WE HAVE INDUSTRY-LEADING WARRANTIES

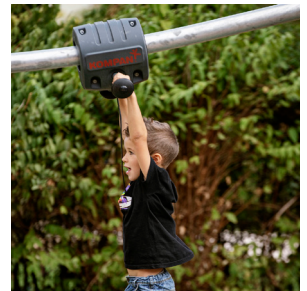

## LIFETIME\* Warranty

- Hot-Dip galvanized parts
- Stainless steel parts
- EcoCore™ and other high-density polyethylene (HDPE) parts

## 15-year warranty

- High-pressure laminate (HPL) parts
- Aluminum parts

## 10-year warranty

- Painted surface on galvanized or aluminum metal parts
- Pre-galvanized posts with painted top layer
- Electrogalvanized metal parts
- Solid plastic parts
- Wood-plastic composite parts
- Robinia, Siberian larch, pine, & other wood types
- Stainless Steel Slides
- Transparent Poly Carbonate (PC) parts
- Hollow plastic parts
- Rope and net constructions

## 5-year warranty

- Resin coated plywood parts
- Springs & ball bearing assemblies
- Graphic print on transparent PC panels
- Concrete parts
- Galaxy connection balls

## 2-year warranty

- Moveable plastic & metal parts
- Rubber membranes
- Screens and electronic parts
- Sunshades & sail solutions

KOMPAN's LIFETIME warranty is in effect for the lifetime of the product until the product is uninstalled and/or taken out of use. In addition, KOMPAN's general terms & delivery conditions apply and supplement this warranty.

## WARRANTY COVERAGE

This warranty applies to KOMPAN's products and spare parts for the time periods described for each product type above and with the limitations described in this warranty. The warranty period applies from the date of purchase by the first customer. This warranty covers only defects in materials. KOMPAN's liability under this warranty is limited to repair or replacement of defective products, without charge, at KOMPAN's discretion. Defective electronic components will be delivered and changed by a KOMPAN ICON Professional installer free of charge.

## PROPER INSTALLATION AND MAINTENANCE

The warranty only applies if KOMPAN's products have been installed according to the instructions provided by KOMPAN and maintained correctly according to the KOMPAN Maintenance Manual. The warranty for the ICON electrical components are dependent on those products being installed by an ICON trained and approved installer.

## WARRANTY EXCLUSIONS

This warranty does not cover any damage caused by accident, improper care, negligence, normal wear and tear, surface corrosion on metal parts, discolored surfaces and other cosmetic issues or failures due to misuse or vandalism. Natural changes in wood over time are considered cosmetic issues and not covered.

## SAFETY STANDARDS

In the interest of playground safety, the International Play Equipment Manufacturers Association (IPEMA) provides a Third Party Certification service whereby a designated independent laboratory, TOV SUD Ameca Inc., (TUV), validates an equipment manufacturer's certification of conformance to the ASTM F1487 standard Consumer Safety Performance Specification for Playground Equipment for Public Use, except sections 7.1.1, 10, 13.1.1, 13.1.2, 13.2, and 13.3; to CAN/CSA Z614 Children's Playpaces and Equipment, except clauses 10 and 11; or both. A list of current validated products and components may be viewed at [www.ipema.org](http://www.ipema.org).

## NEAR WATER INSTALLATIONS

Products installed in direct contact with chlorinated water or saltwater (waterparks), or products installed within 650 feet from the shore are not covered by the KOMPAN warranty for any defects caused by corrosion.

Specially designed products (handled Variant department for customized products and upgraded to corrosion class C4) installed within 650 feet from the shore will be covered by 5 years of warranty in relation to structural defects caused by corrosion.

## THIRD-PARTY SUPPLIED PRODUCTS & SERVICES

KOMPAN provides non-KOMPAN branded products and installation services performed by certified third-party suppliers. This general KOMPAN warranty does not apply to such non-KOMPAN branded products and installation services, which may carry their own warranties. KOMPAN will pass on information on such warranties where possible.

## FREIGHT AND WAREHOUSING

Global transport and logistics arranged by KOMPAN appointed forwarder. Products/items are not to be stored outside waiting for installation and must be kept dry at all times.



**EXHIBIT-B**

**PLAY STRUCTURE: LITTLE FOX SHOP**

**KOMPAN!**

NRO418

ID ----

MarPri

2024-04-04

Colorline: Untreated  
Foundation: 100 cm wood  
Norm: ---  
Units: cm  
Certification FSC: No

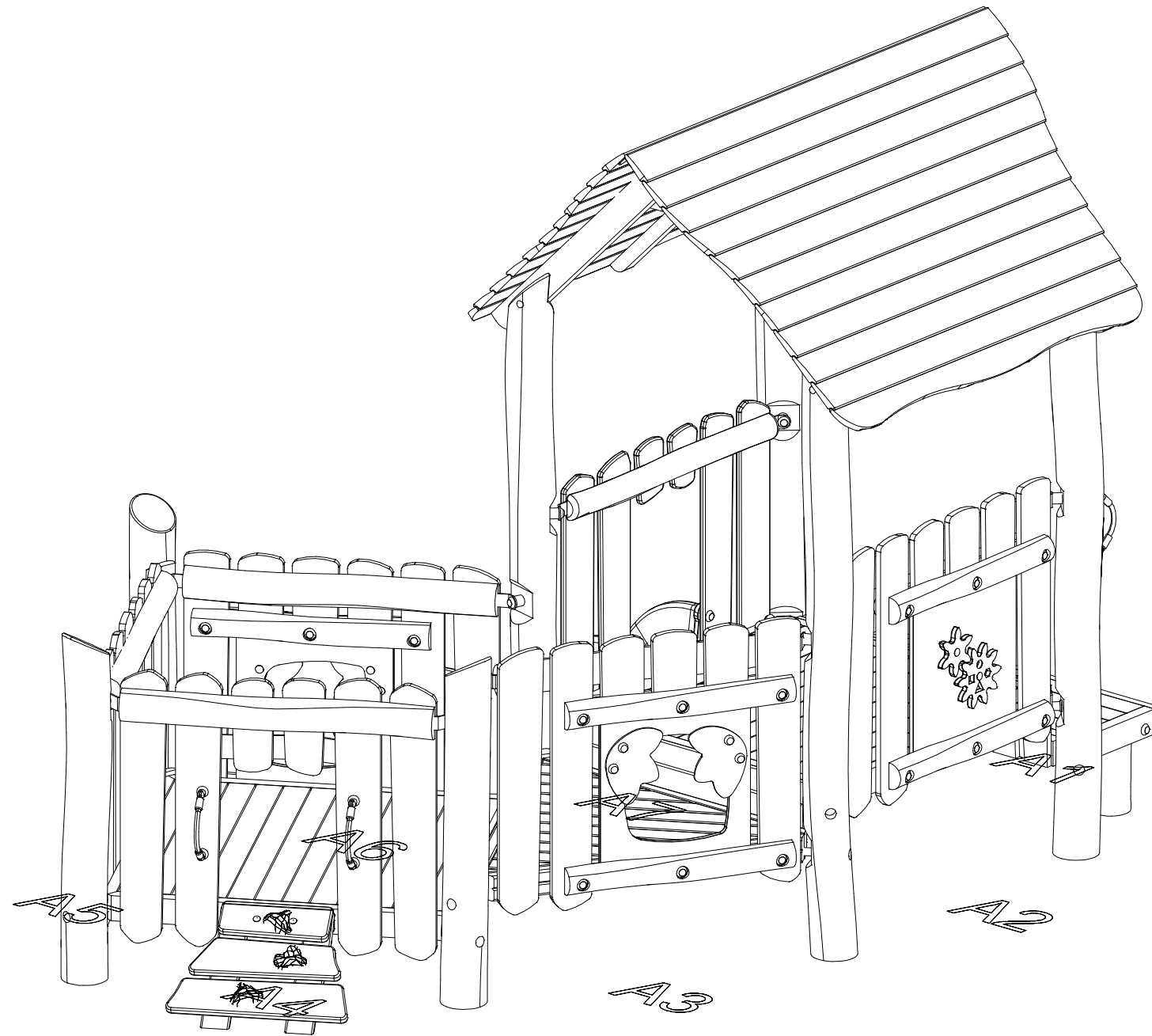

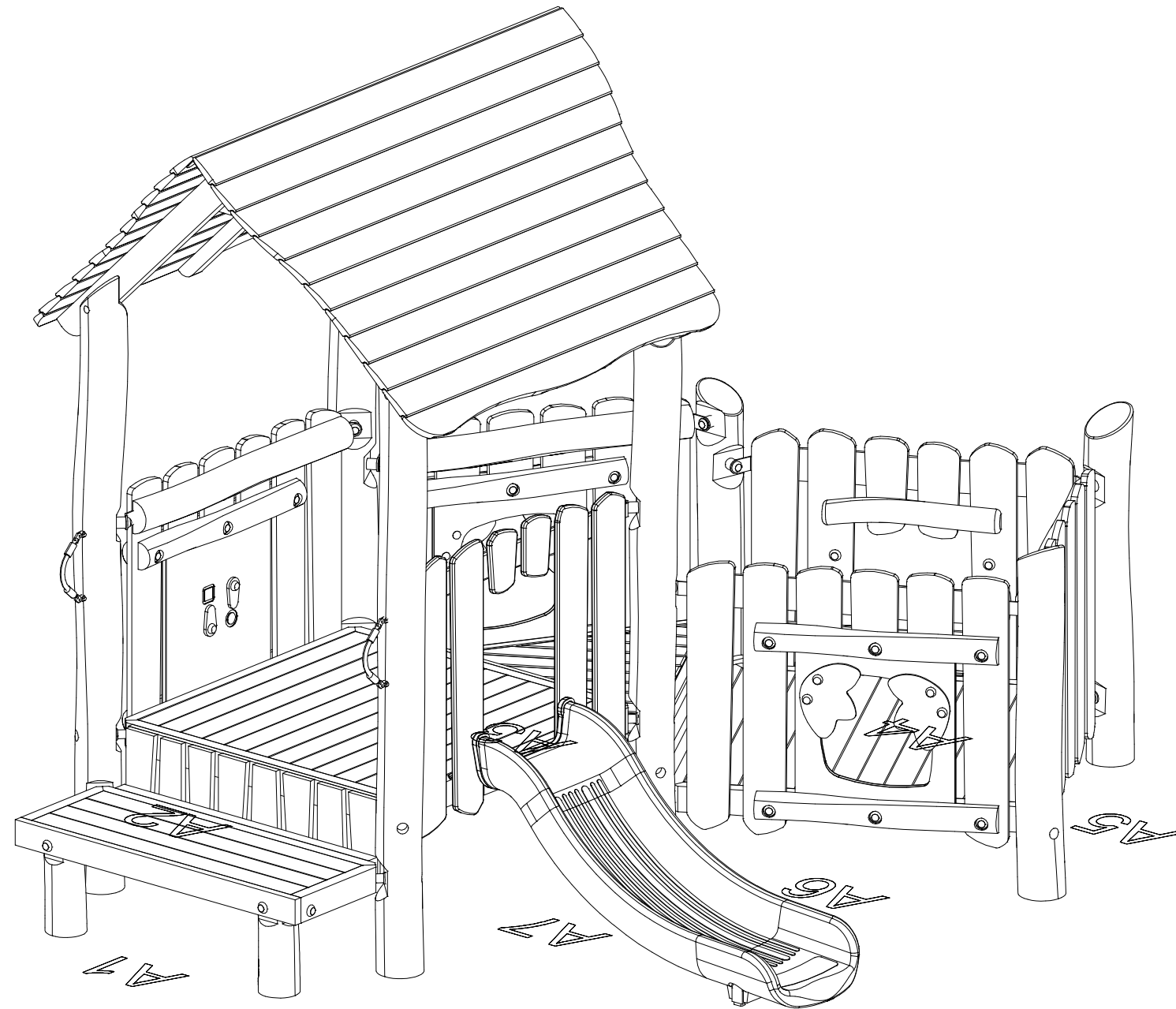

NRO418

ID ----

MarPri

2024-04-04

EN1176

Scale: MAX

Foundation: 100 cm wood

All Unspecified Holes

0.266 m<sup>3</sup> 9.394 cu.ft.



Concrete - Béton - Hormigón  
Cemento - Beton - Belong - Beton  
Бетон - Betonointi - Betão

**C25/30 (B25)**

$f_{ck,cube} = 30 \text{ N/mm}^2$

Use the specified quality of concrete in accordance with all specifications from the concrete supplier taking the nature of the product to be installed into account.

**Safety Zone**

Perimeter: 20 m

Area: 29.2 m<sup>2</sup>

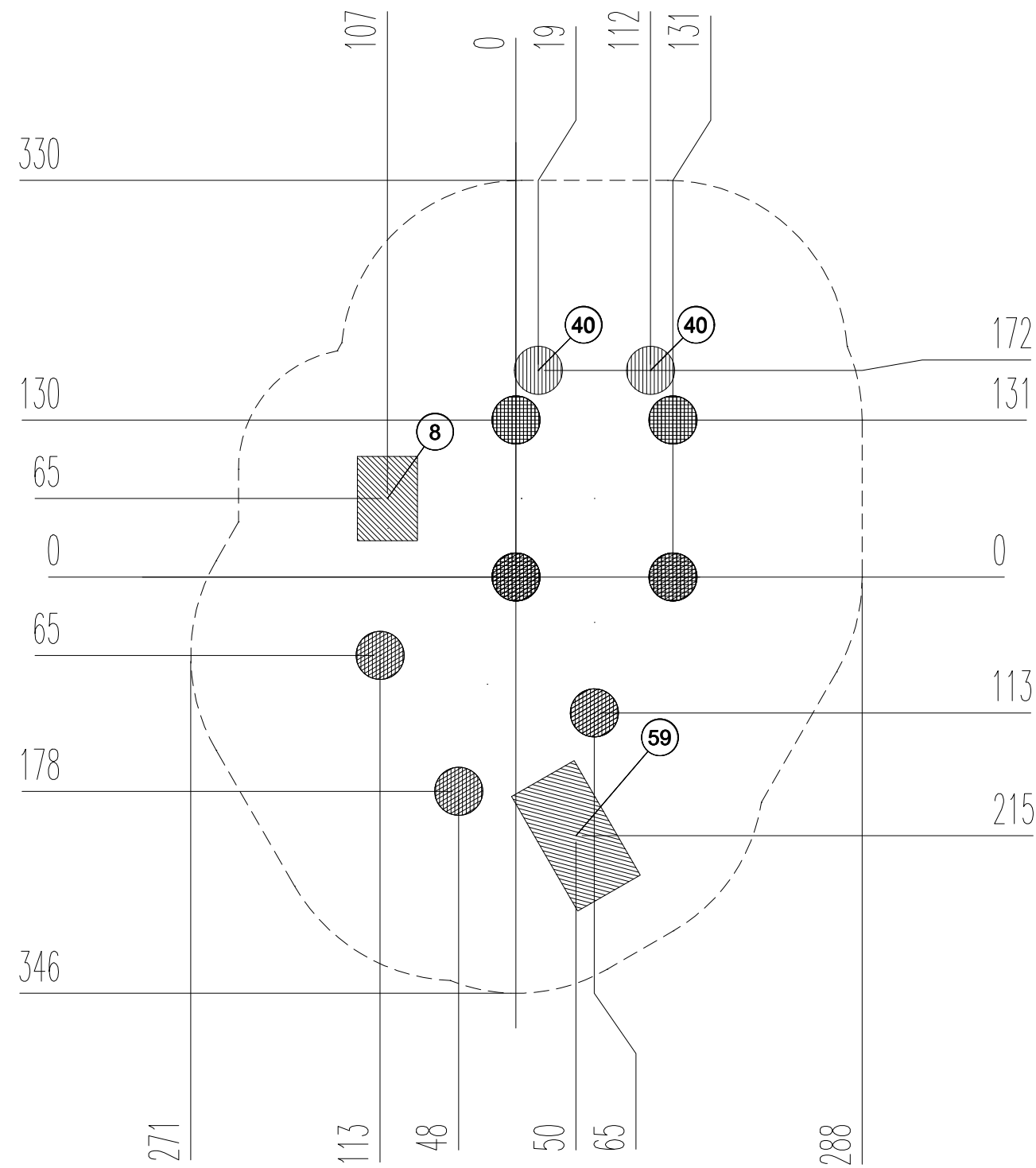
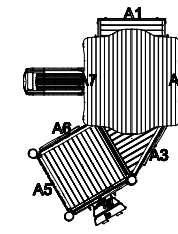

All Unspecified Holes

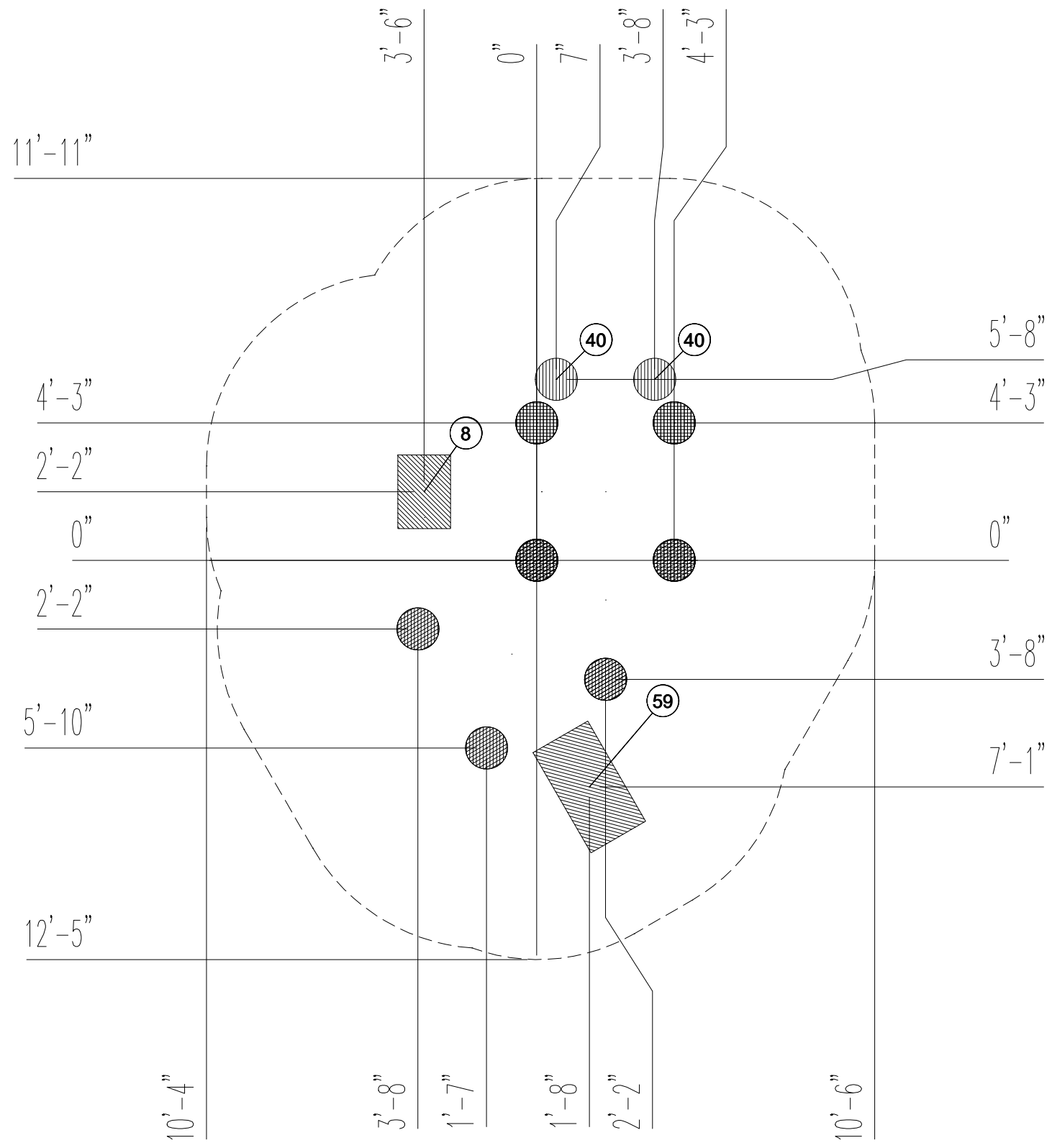
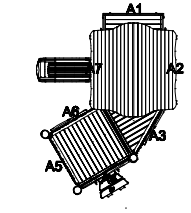

0.266 m<sup>3</sup> 9.394 cu.ft.



Concrete - Béton - Hormigón  
 Cemento - Beton - Belong - Beton  
 Бетон - Betonointi - Betão

C25/30 (B25)

$f_{ck,cube} = 30 \text{ N/mm}^2$   
 Use the specified quality of concrete  
 in accordance with all specifications  
 from the concrete supplier taking  
 the nature of the product to be  
 installed into account.

### Safety Zone

Perimeter: 73 ft  
 Area: 403.6 ft<sup>2</sup>

NRO418

ID ----

MarPri

2024-04-04

CSA Z614

Scale: MAX

Foundation: 100 cm wood

All Unspecified Holes

0.266 m<sup>3</sup> 9.394 cu.ft.



Concrete - Béton - Hormigón  
Cemento - Beton - Belong - Beton  
Бетон - Betonointi - Betão

C25/30 (B25)

$f_{ck,cube} = 30 \text{ N/mm}^2$

Use the specified quality of concrete in accordance with all specifications from the concrete supplier taking the nature of the product to be installed into account.

**Safety Zone**

Perimeter: 23 m

Area: 37.5 m<sup>2</sup>

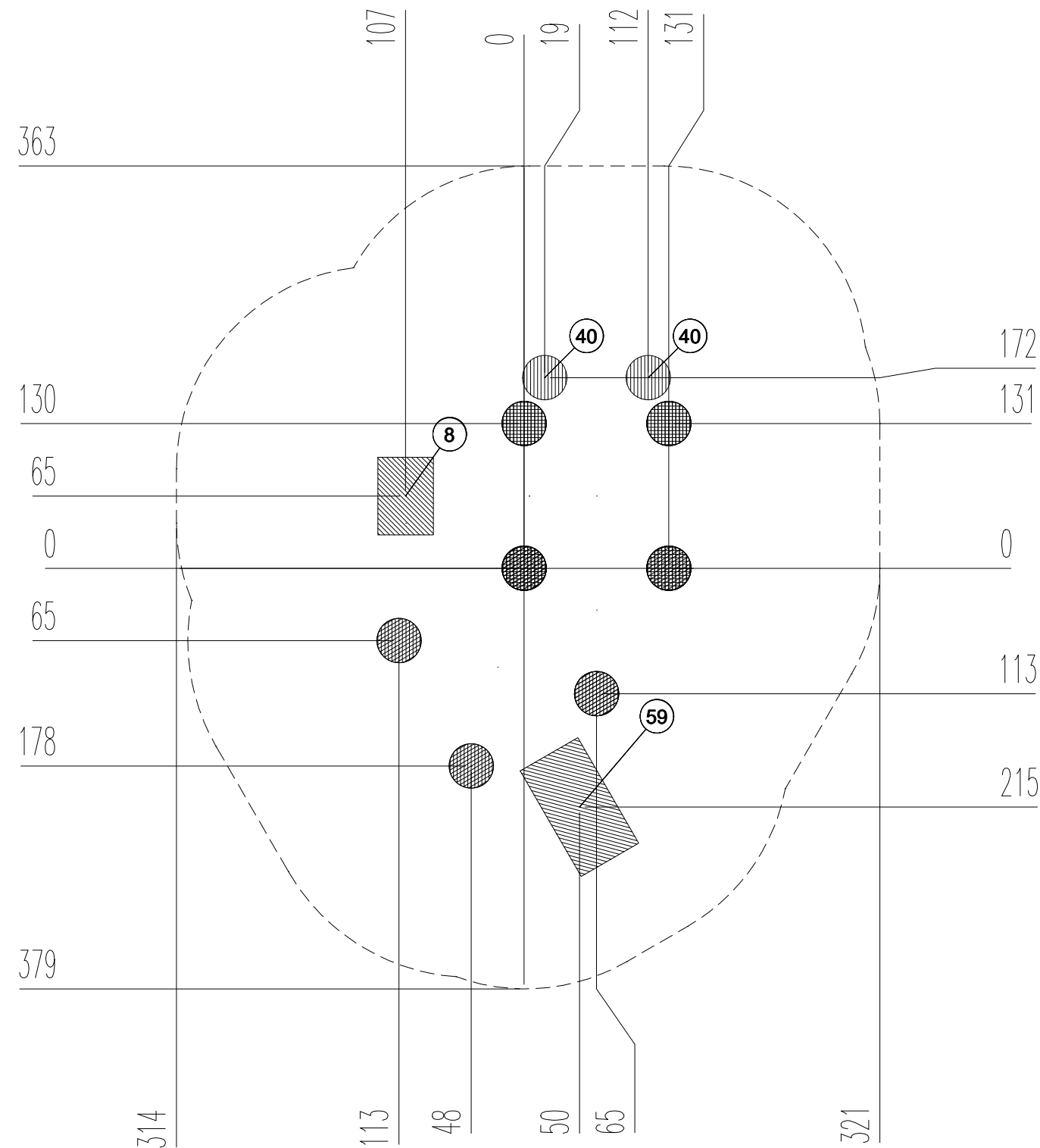
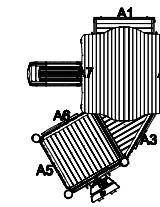

All Unspecified Holes

0.266 m<sup>3</sup> 9.394 cu.ft.



Concrete - Béton - Hormigón  
Cemento - Beton - Belong - Beton  
Бетон - Betonointi - Betão

**C25/30 (B25)**

$f_{ck,cube} = 30 \text{ N/mm}^2$

Use the specified quality of concrete in accordance with all specifications from the concrete supplier taking the nature of the product to be installed into account.

**Safety Zone**

Perimeter: 20 m

Area: 29.2 m<sup>2</sup>

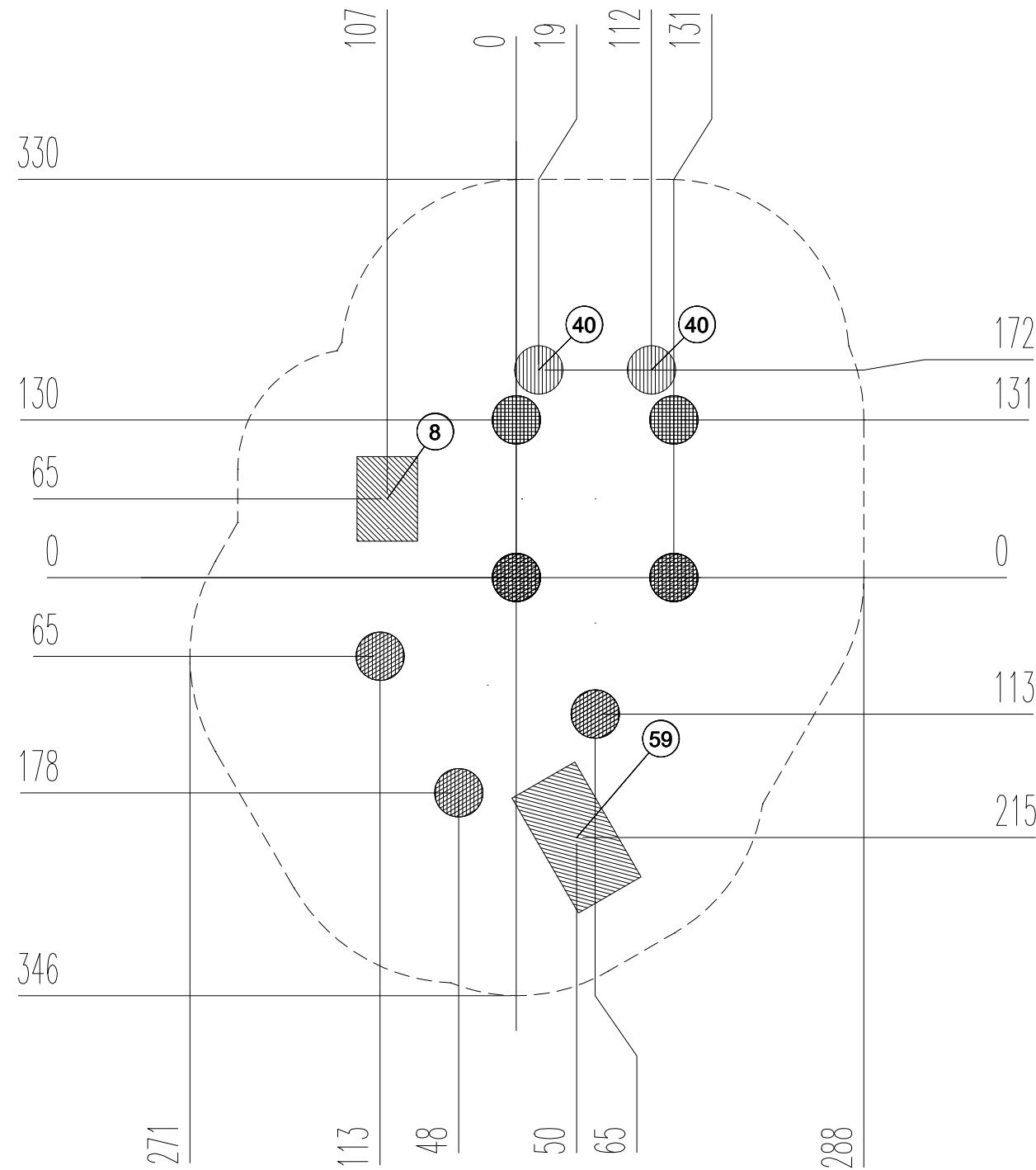
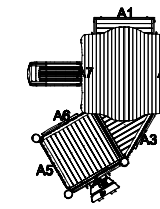

# KOMPAN® NRO418

ID ----

LUK CER

2020-12-03

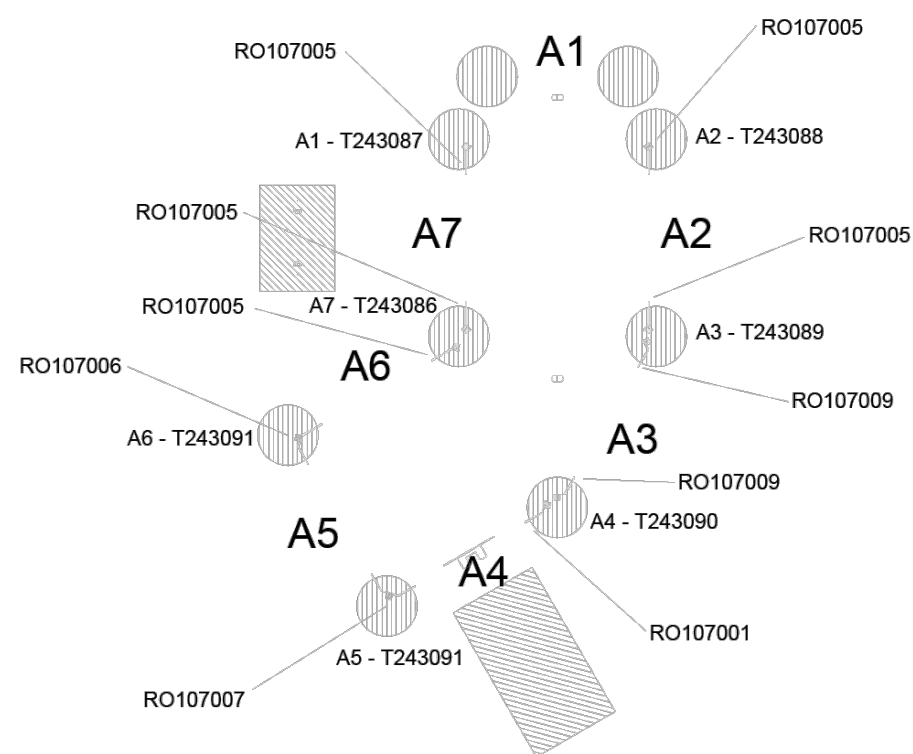
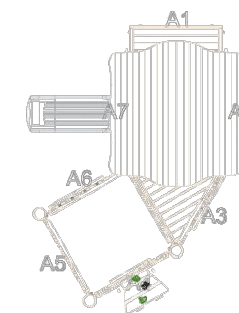

RO107001-0001	A240003-51	
RO107002-0001	A240004-51	
RO107003-0001	A240012-51	
RO107004-0001	A240013-51	
RO107005-0001	A240023-51	
RO107006-0001	A240024-51	
RO107007-0001	A240025-51	
RO107008-0001	A240073-51	
RO107009-0001	A240074-51	

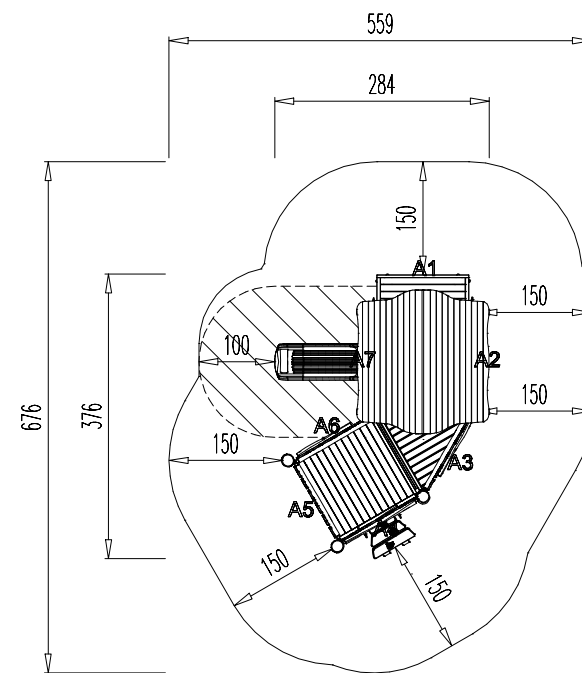
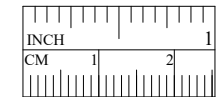
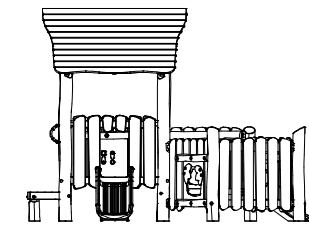
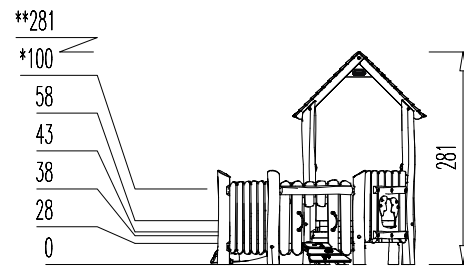

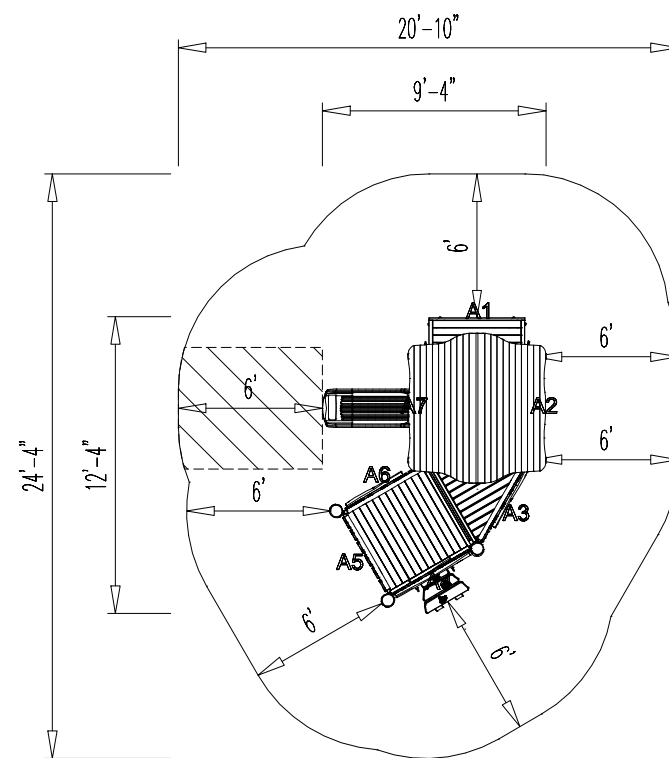
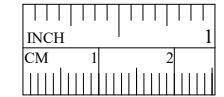
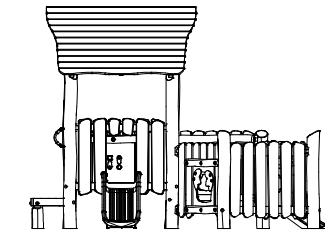
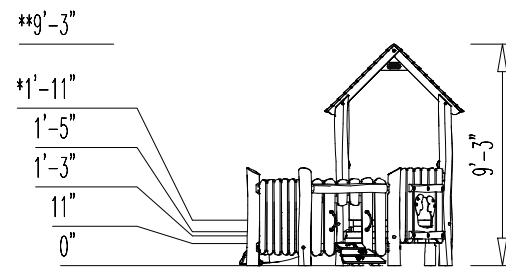

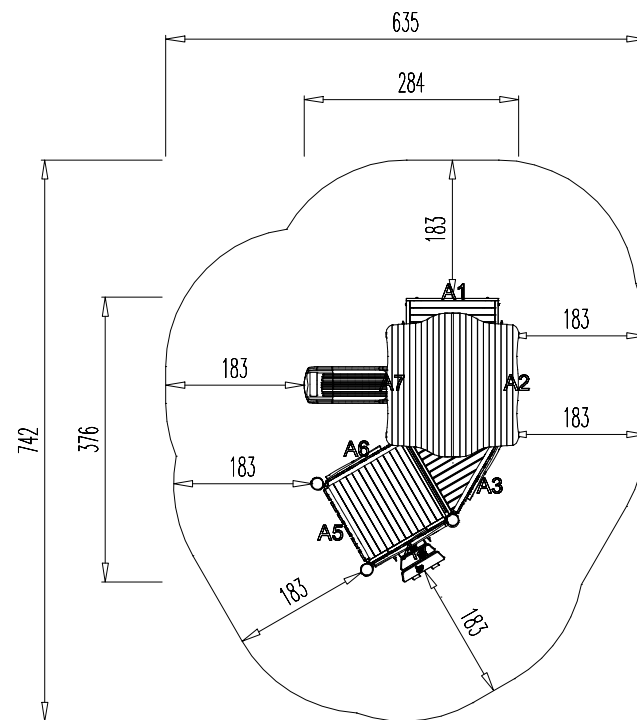
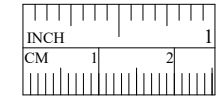
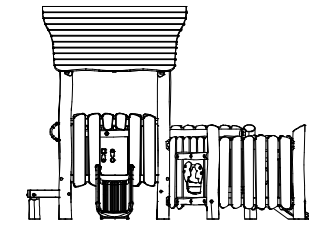
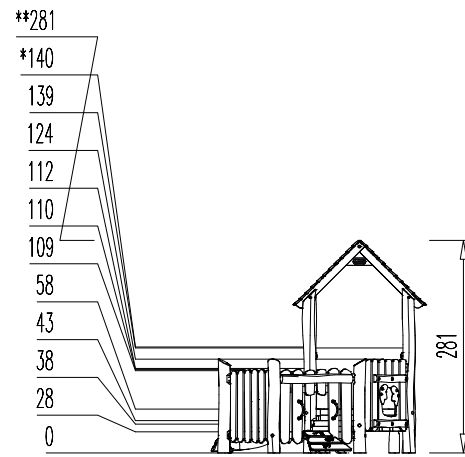

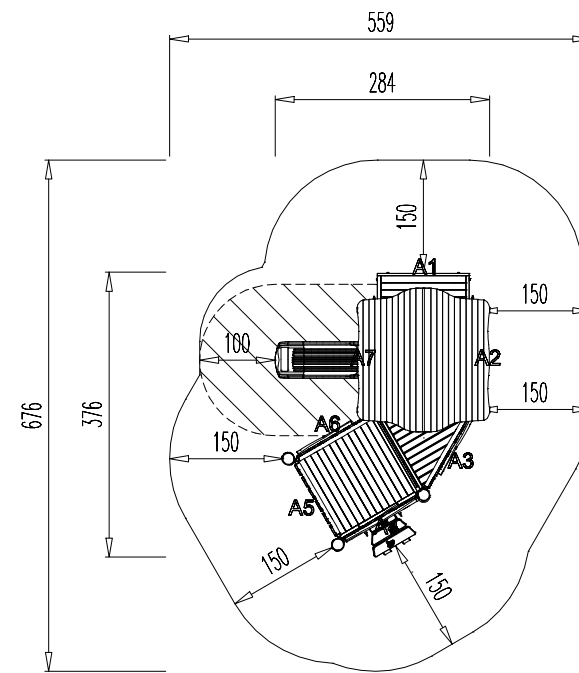
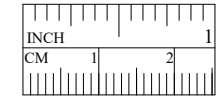
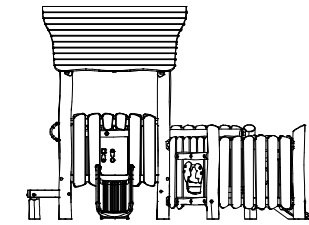
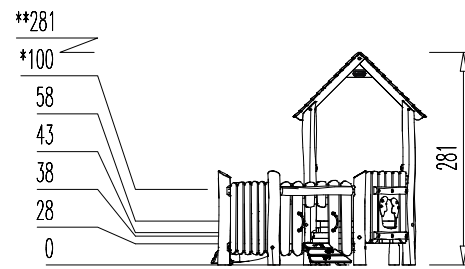

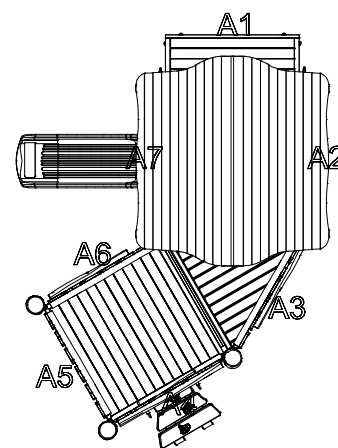

TOWER-A



RO150021-1001



2x RO113066-0001



A1-RO109016-1001



A2-RO113078-0001



A2-RO120127-0001



A3-RO113076-0001



A3-RO120127-0001



A4-RO120137-0001



A4-RO116028-0501



A5-RO120128-0001



A6-RO120127-0001



A6-RO113076-0001



A7-RO126058-0601



A7-RO120129-0001

OTHERS



2x RO109001-0001



RO109003-0001



RO120131-0001



2x RO120125-0001



RO108011-0001





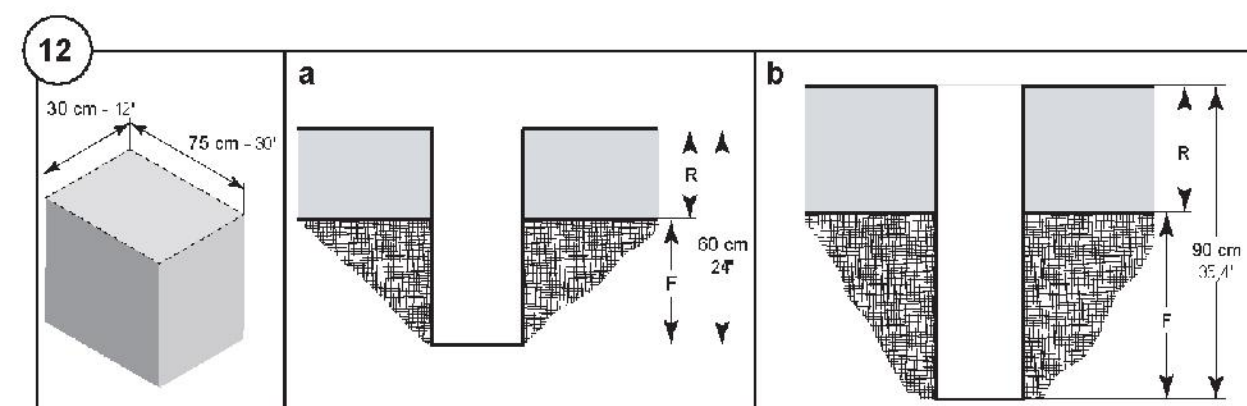
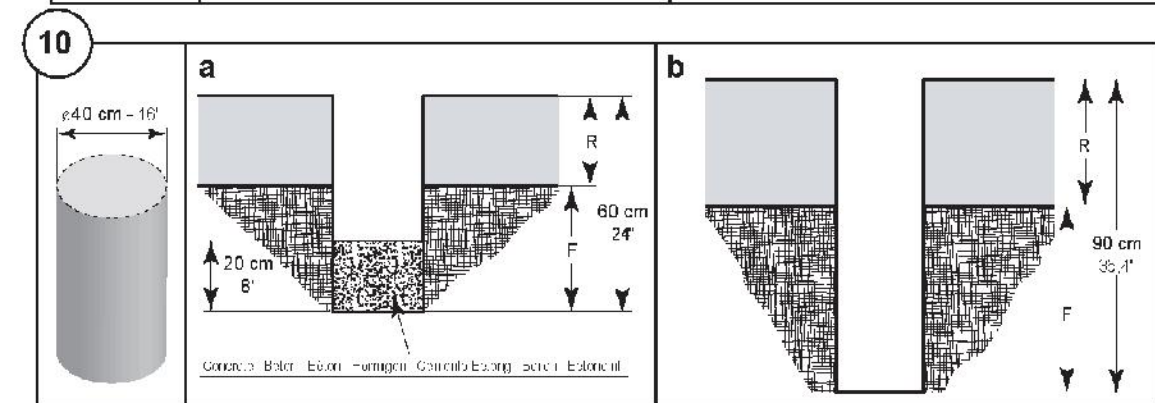
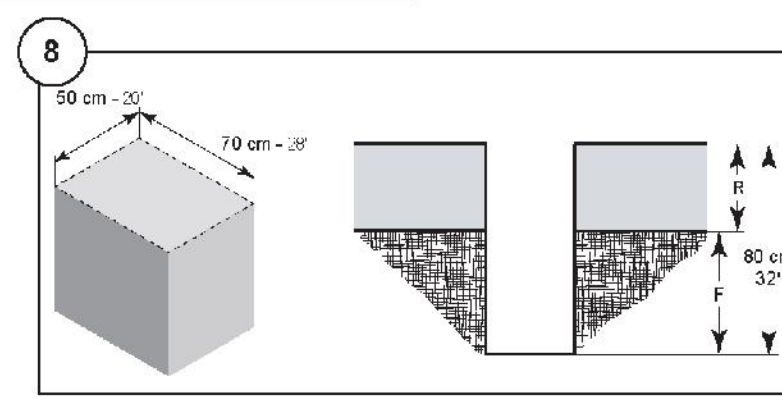
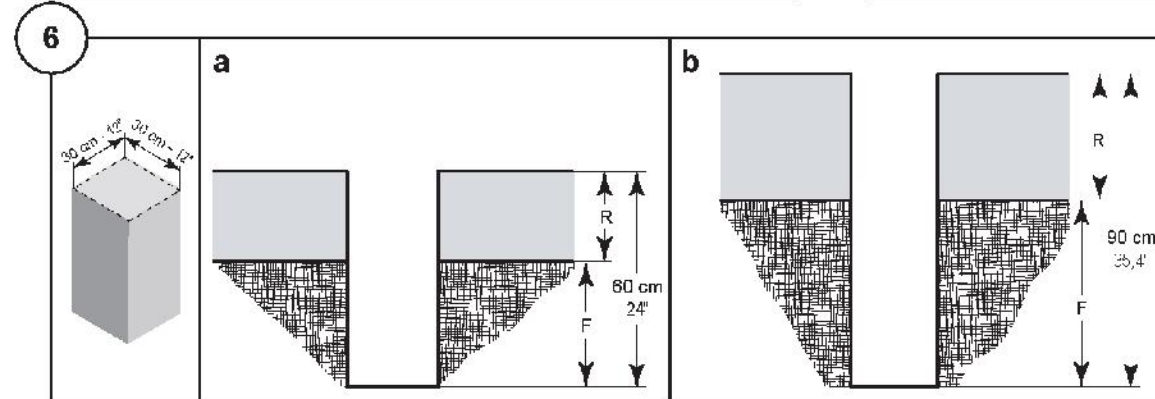
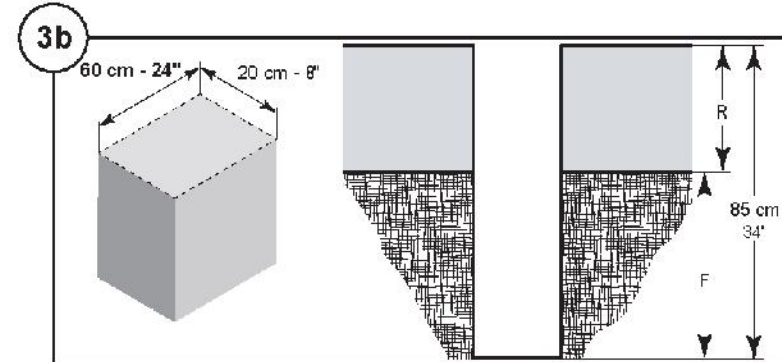
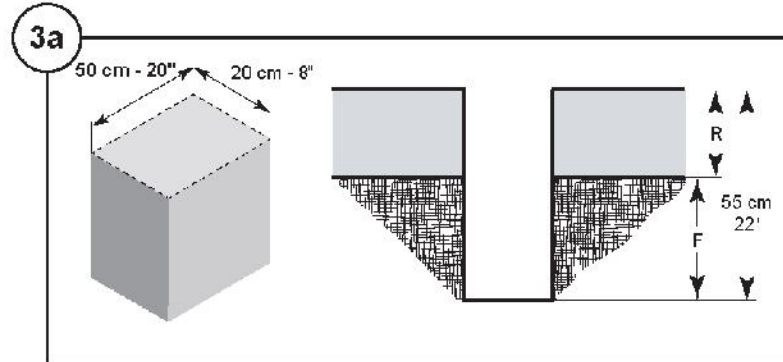
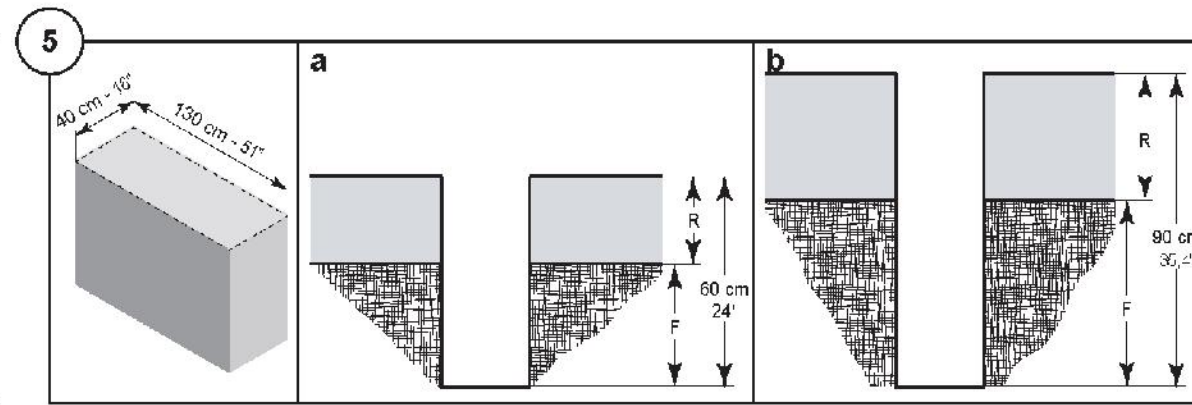
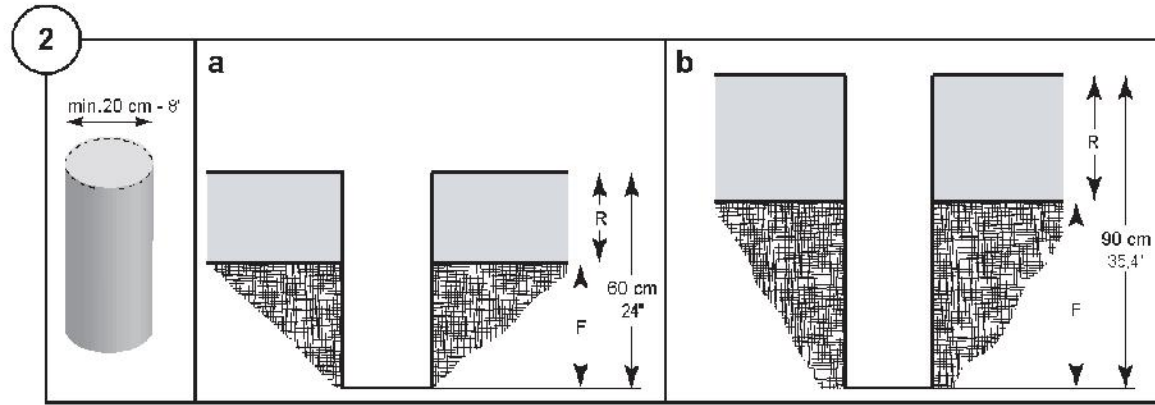

**Important!** The concrete (C25/30) must be sufficiently hardened before the play item may be used.  
**Wichtig!** Vor der Inbetriebnahme des Spielgeräts muß der Beton (C25/30) ausreichend abgehenden haben.  
**Important!** Le béton (C25/30) doit avoir suffisamment durci avant de mettre en service l'équipement de jeux.  
**Importante!** El hormigón (C25/30) debe estar suficientemente endurecido antes de comenzar a utilizar el equipo de juego.  
**Importante!** Prima de utilizzare le attrezzature da gioco, il cemento (C25/30) deve essere sufficientemente solidificato.  
**Belangrijk!** Het beton (C25/30) moet voldoende gehard zijn voordat het speeltoestel in gebruik wordt genomen.  
**Viktigt!** Betongen (C25/30) måste ha hårdat tillräckligt innan lekredskapet börjar användas.  
**Viktigt!** Betonen (C25/30) skal være tilstrækkeligt hærdet, før legeredskabet tages i brug.  
**Важно!** Перед использованием сооружений убедитесь, что бетон (C25/30) затвердел.  
**HUOM!** Betonivalun (C25/30) on oltava tarpeeksi kuiva, ennen kuin leikkivälineitä saa käyttää.

R: Resilient surfacing - Fallschutzbelag  
 Revêtement amortissant - Recubrimiento amortiguador - Materiale ammortizzante  
 Veiligheidsondergrond - Fallunderlag  
 Faldunderlag - Безопасное покрытие  
 Turva-alusta

F: Foundation - Fundament - Fondement  
 Fondazione - Fundamento - Fonden - Stiftelsen  
 Perustus - Stichting - Фонд

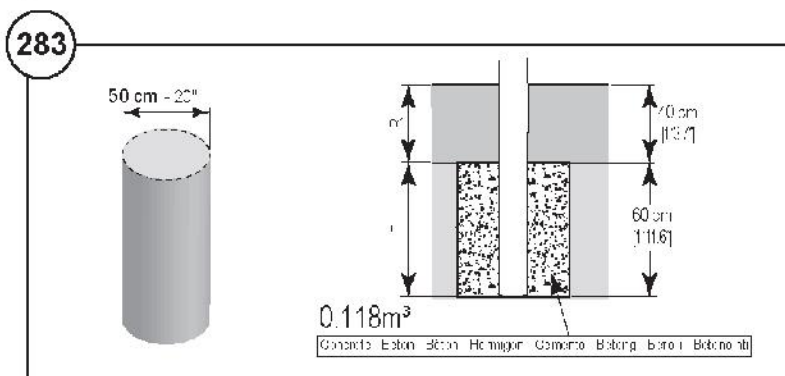
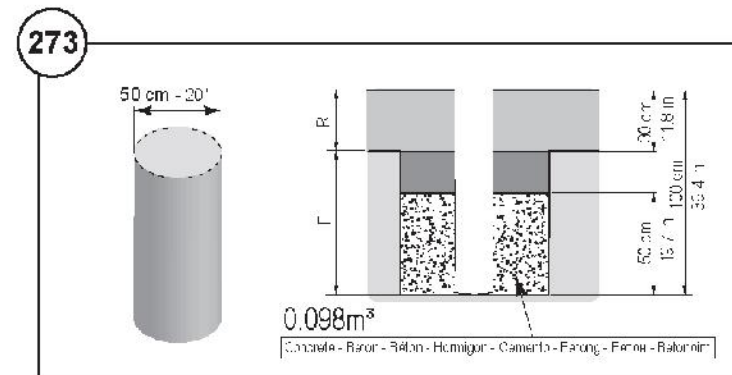
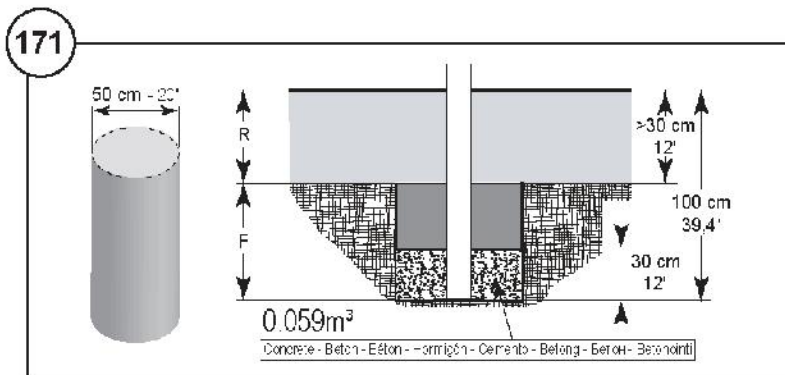
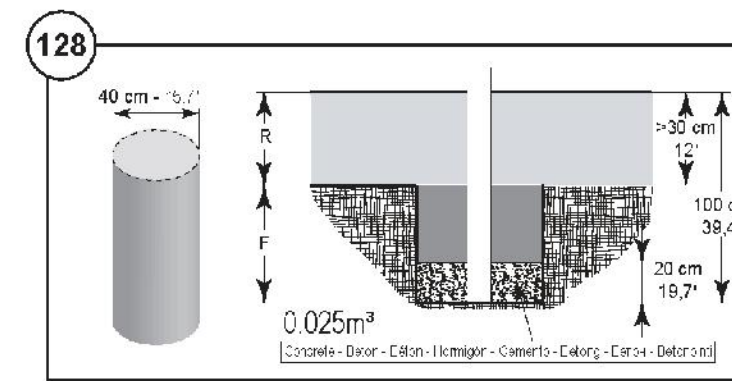
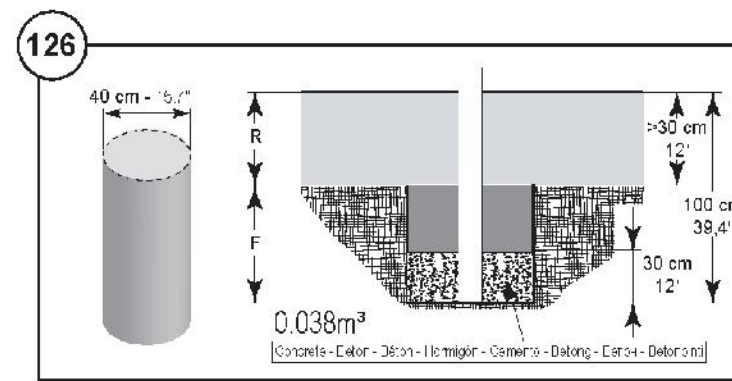
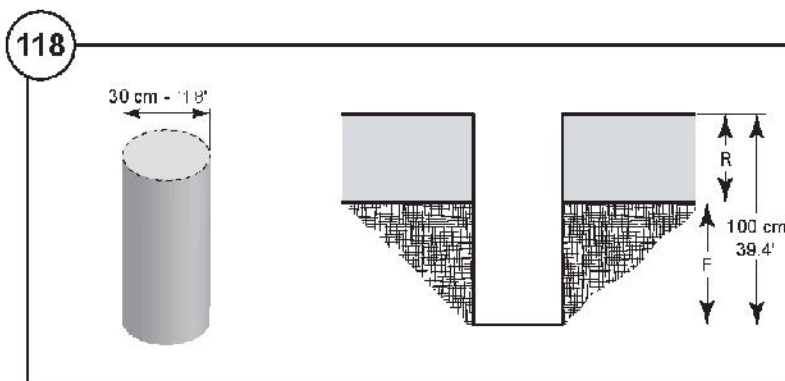
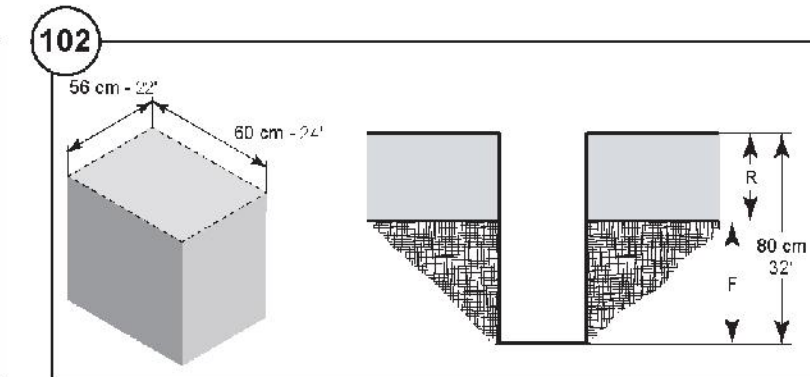
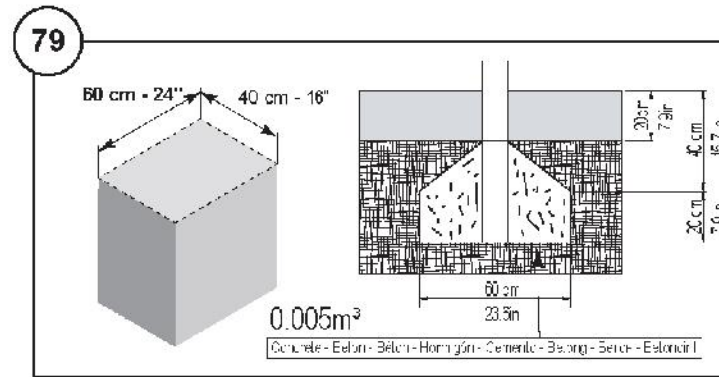
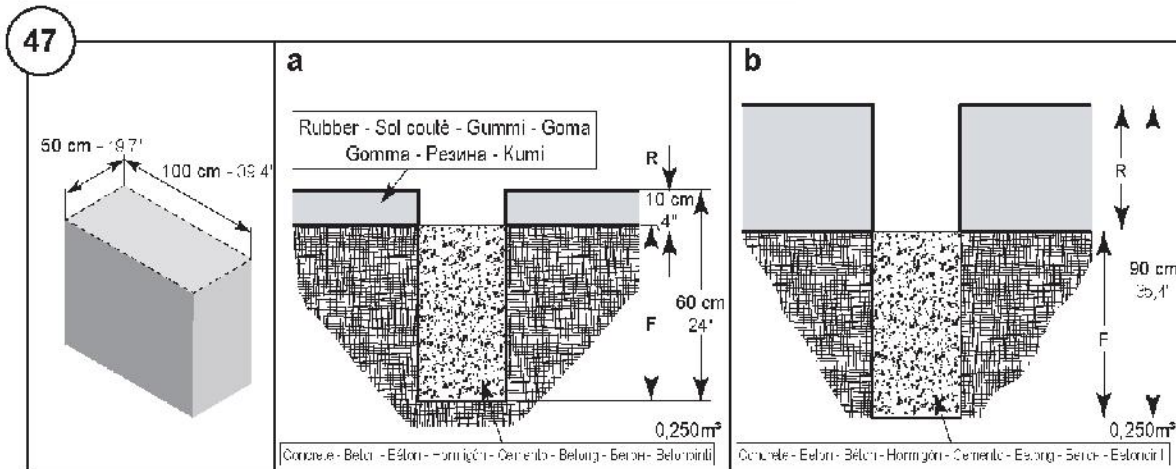
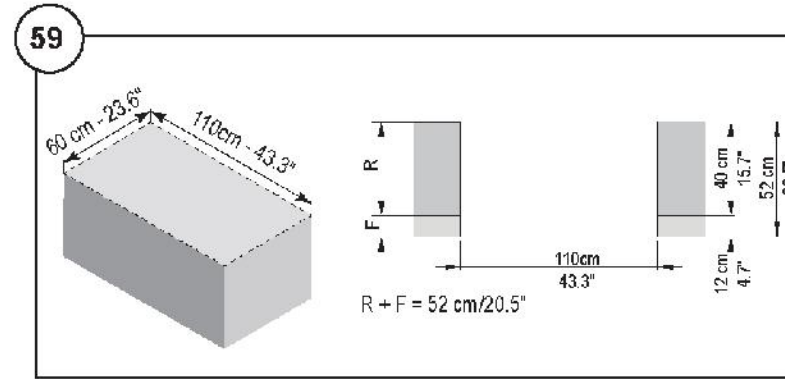
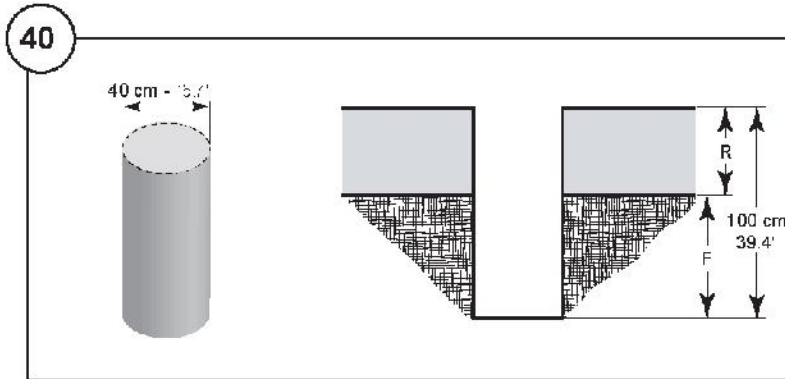

**Important!** The concrete (C25/30) must be sufficiently hardened before the play item may be used.  
**Wichtig!** Vor der Inbetriebnahme des Spielgeräts muß der Beton (C25/30) ausreichend abgehenden haben.  
**Important!** Le béton (C25/30) doit avoir suffisamment durci avant de mettre en service l'équipement de jeux.  
**Importante!** El hormigón (C25/30) debe estar suficientemente endurecido antes de comenzar a utilizar el equipo de juego.  
**Importante!** Prima de utilizzare le attrezzature da gioco, il cemento (C25/30) deve essere sufficientemente solidificato.  
**Belangrijk!** Het beton (C25/30) moet voldoende gehard zijn voordat het speeltoestel in gebruik wordt genomen.  
**Viktigt!** Betongen (C25/30) måste ha härdat tillräckligt innan lekredskapet börjar användas.  
**Vigtigt!** Betonen (C25/30) skal være tilstrækkeligt hærdet, før legeredskabet tages i brug.  
**Важно!** Перед использованием сооружений убедитесь, что бетон (C25/30) затвердел.  
**HUOM!** Betonivalun (C25/30) on oltava tarpeeksi kuiva, ennen kuin leikkivälinettä saa käyttää.

R: Resilient surfacing - Fallschutzbelag  
 Revêtement amortissant - Recubrimiento amortiguador - Materiale ammortizzante  
 Veiligheidsondergrond - Fallunderlag  
 Faldunderlag - Безопасное покрытие  
 Turva-alusta

F: Foundation - Fundament - Fondement  
 Fondazione - Fundamento - Fonden - Stiftelsen  
 Perustus - Stichting - Фонд

**EXHIBIT-B**

PLAY STRUCTURE: ROBINIA TOWER WITH SLIDE



**KOMPAN®**

**NRO936417**

2026.01.21 TomVag

Copyright © KOMPAN A/S

Footing: Wood

Version: Colored (-30)



*Colored roof -0030, colored nets orange -197*

Overview

**KOMPAN!**

NRO-CUSTOM

ID 936417

TomVag

2026-01-21

Colorline:	#
Foundation:	100 cm wood
Norm:	ASTMF1487
Units:	feet
Post material:	Robinia
Post colors:	-

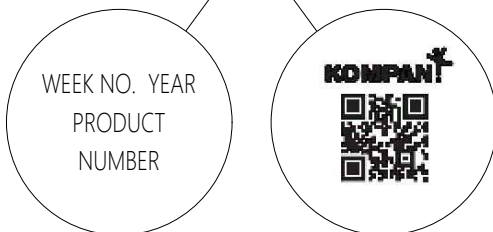

Overview

**KOMPAN!**

NRO-CUSTOM

ID 936417

TomVag

2026-01-21



RO118088



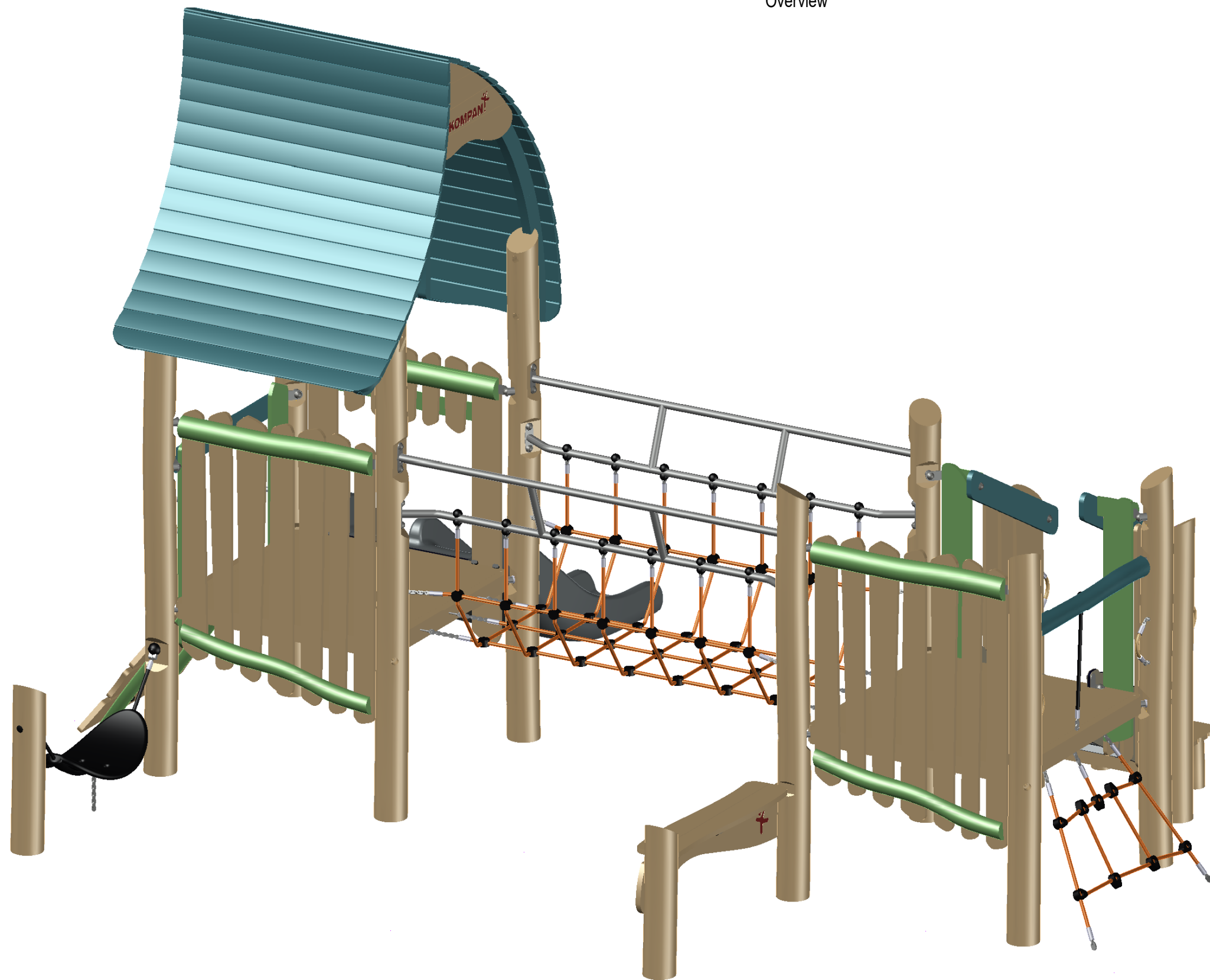

Tower & Side Overview

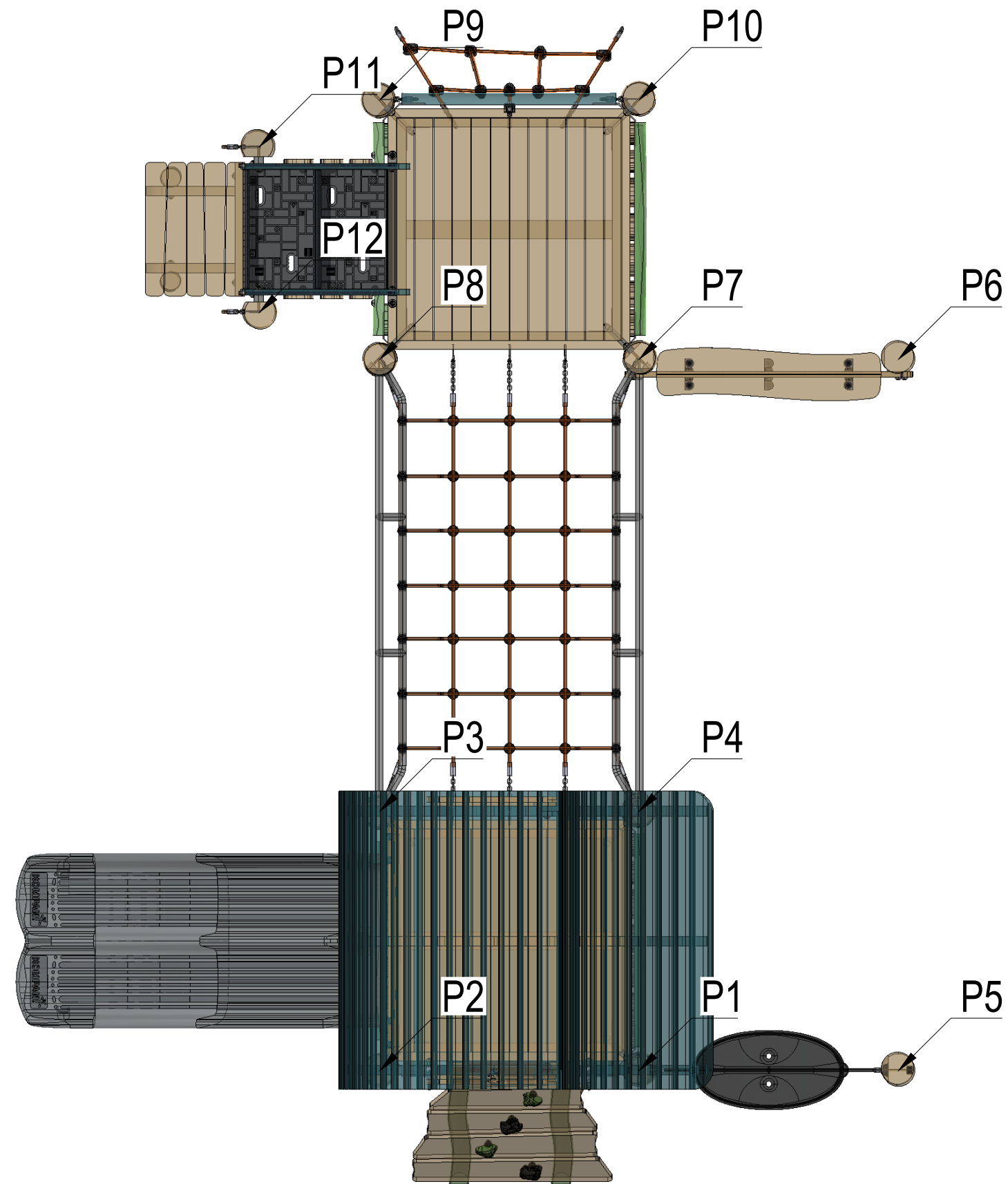

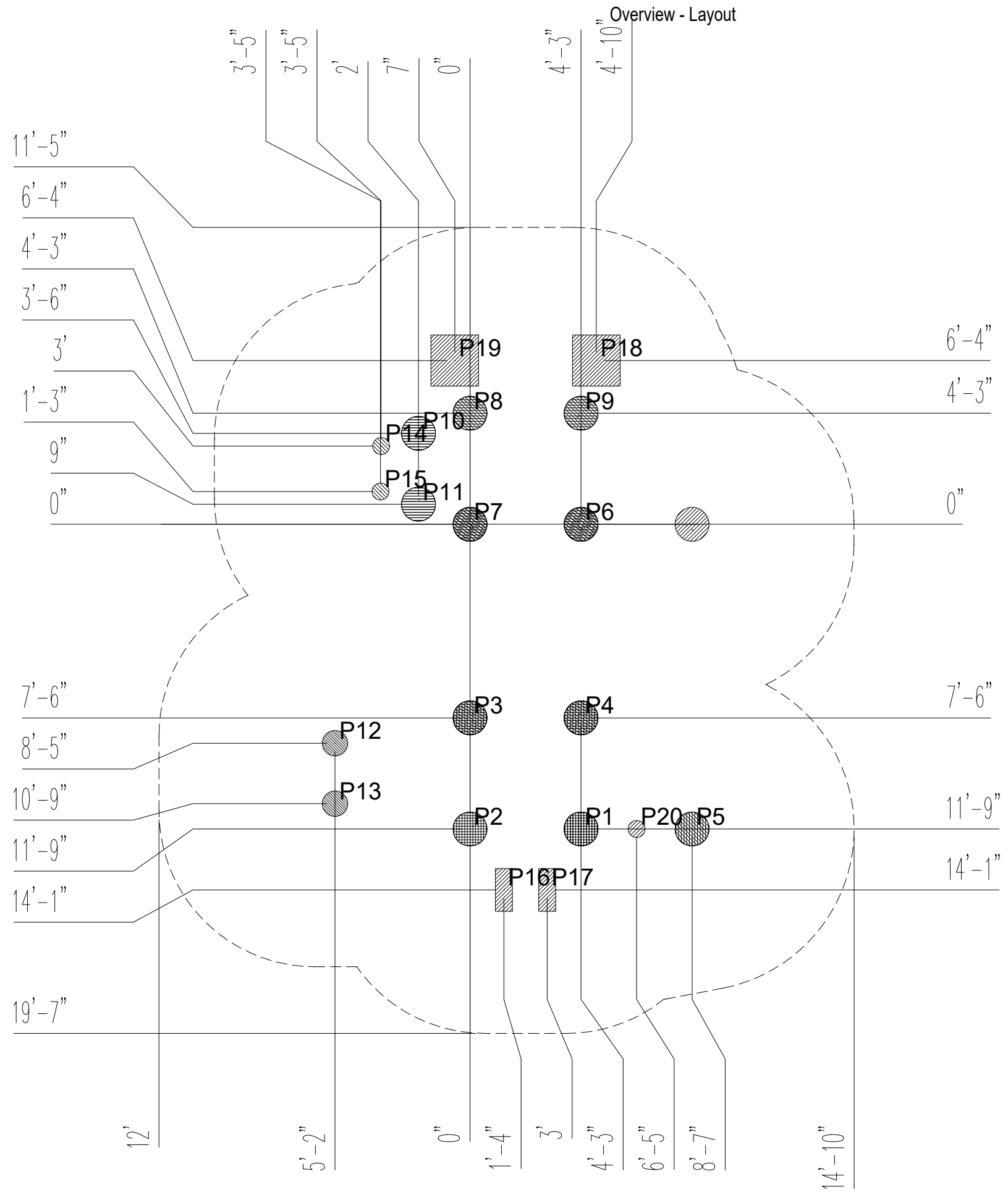

# KOMPAN!

NRO-CUSTOM

ID 936417

TomVag

2026-01-21

Scale: ###

Units: inch

Safety zone

- Norm: ASTM F1487
- Perimeter: 101 ft
- Area: 669.2 ft<sup>2</sup>

Concrete

- Volume: 11.619 CU.FT.



C25/30 (B25)

$f_{ck,cube} = 30 \text{ N/mm}^2$

Use the specified quality of concrete in accordance with all specifications from the concrete supplier taking the nature of the product to be installed into account.

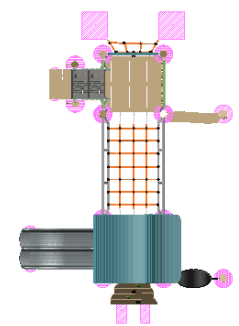

Overview of used Digging Holes and Footings



NRO-CUSTOM

ID 936417

TomVag

2026-01-21

Foundation				Footing for Posts / Modules					
Pos.	Hole Type	Profile [cm]	Depth [cm]	Pos.	Module No.	Profile [mm]	Length [cm]	Footing module	Post cap
P1-P4	126	ø40	100	P1	TV05A-3000-10027	-	300	-	-
P5	128	ø40	100	P2-P3	TV04A-3000-10027	-	300	-	-
P6-P9	126	ø40	100	P4	TV05A-3000-10027	-	300	-	-
P10-P11	40	ø40	100	P5	TV01A-1000-10027	-	100	-	-
P12-P13	124	ø30	80	P6-P9	TV01A-2500-10027	-	250	-	-
P14-P15	1	ø20	85	P10-P11	TV06B-2000-10027	-	200	-	-
P16-P17	3	20x50	85	P12-P13	RO128088-0801	-	-	-	-
P18-P19	102	56x60	80	P14-P15	RO117088-0621	-	-	-	-
				P16-P17	RO116088-0521	-	-	-	-
				P18-P19	-	-	-	-	-

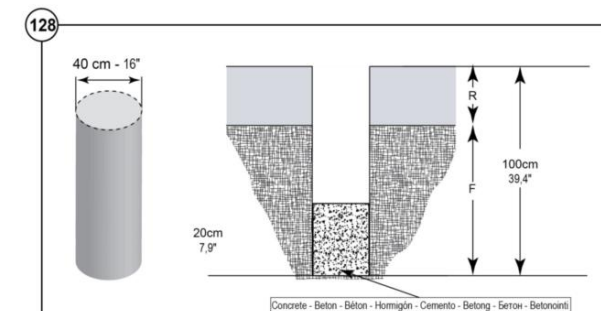
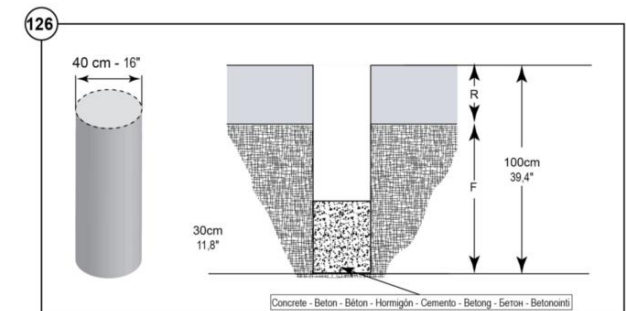
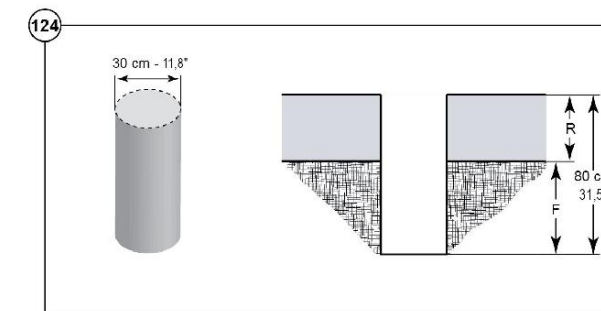
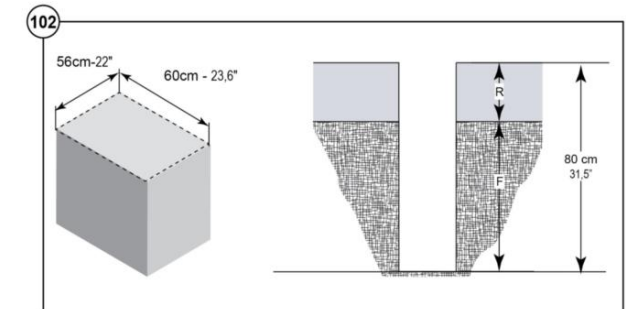
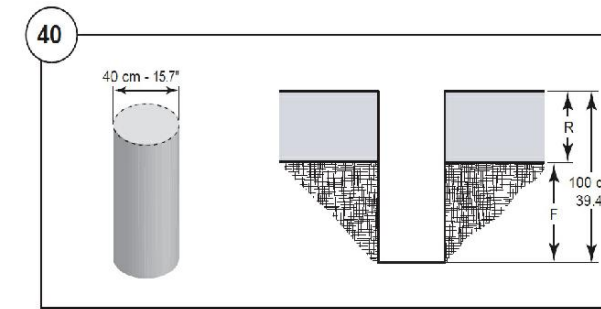
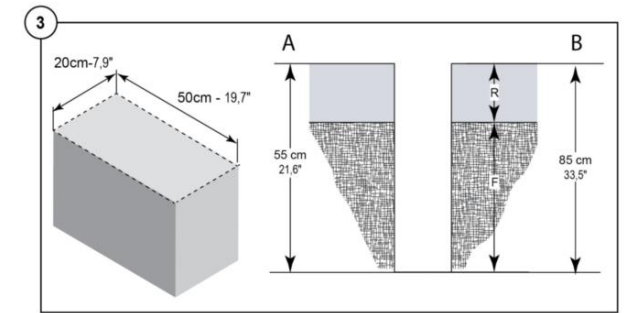
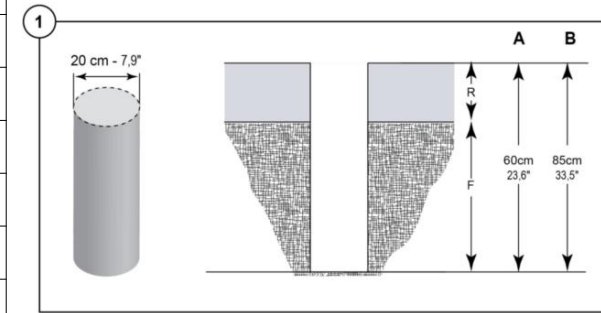

Overview of used Digging Holes and Footings

Foundation				Footing for Posts / Modules					
Pos.	Hole Type	Profile [cm]	Depth [cm]	Pos.	Module No.	Profile [mm]	Length [cm]	Footing module	Post cap
P21	2B	ø20	90	P21	RO113057-0601	-	-	-	-

**KOMPAN!**

NRO-CUSTOM

ID 936417

TomVag

2026-01-21

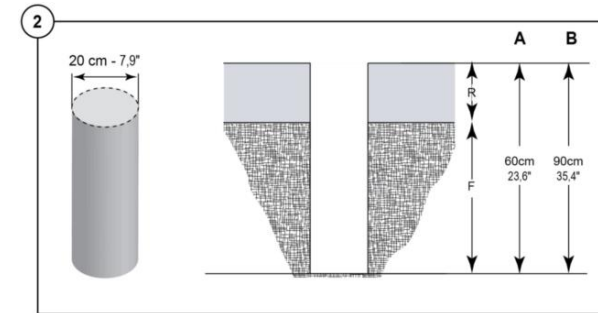

Safety zone / Fall height

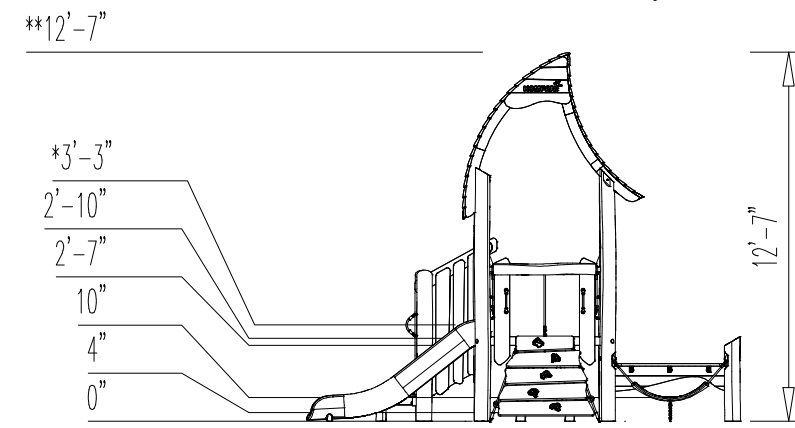

NRO-CUSTOM

ID 936417

TomVag

2026-01-21

Scale: ###

Units: inch

ASTM F1487

\* Fall height

\*\* Total height

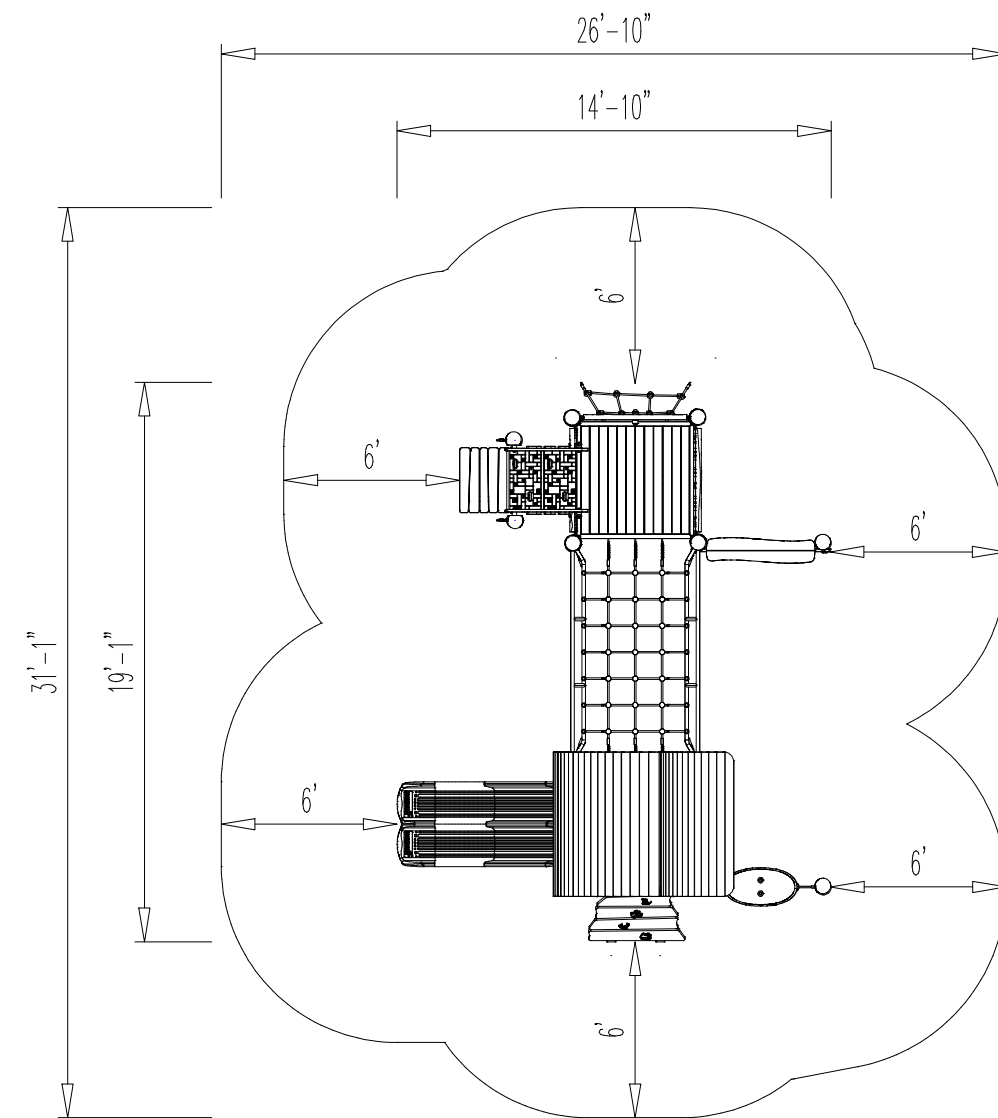

Overview

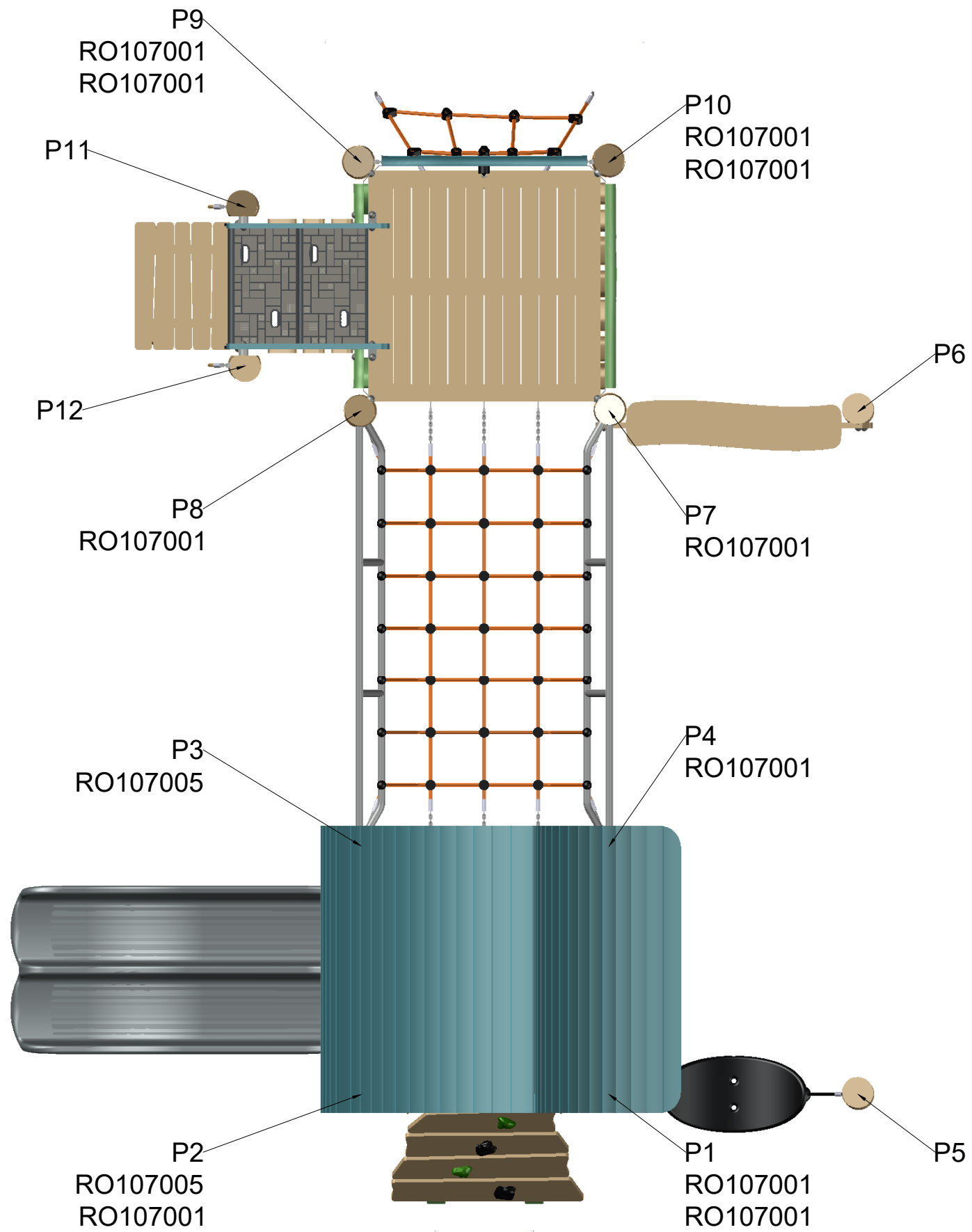





NRO-CUSTOM

ID 936417

TomVag

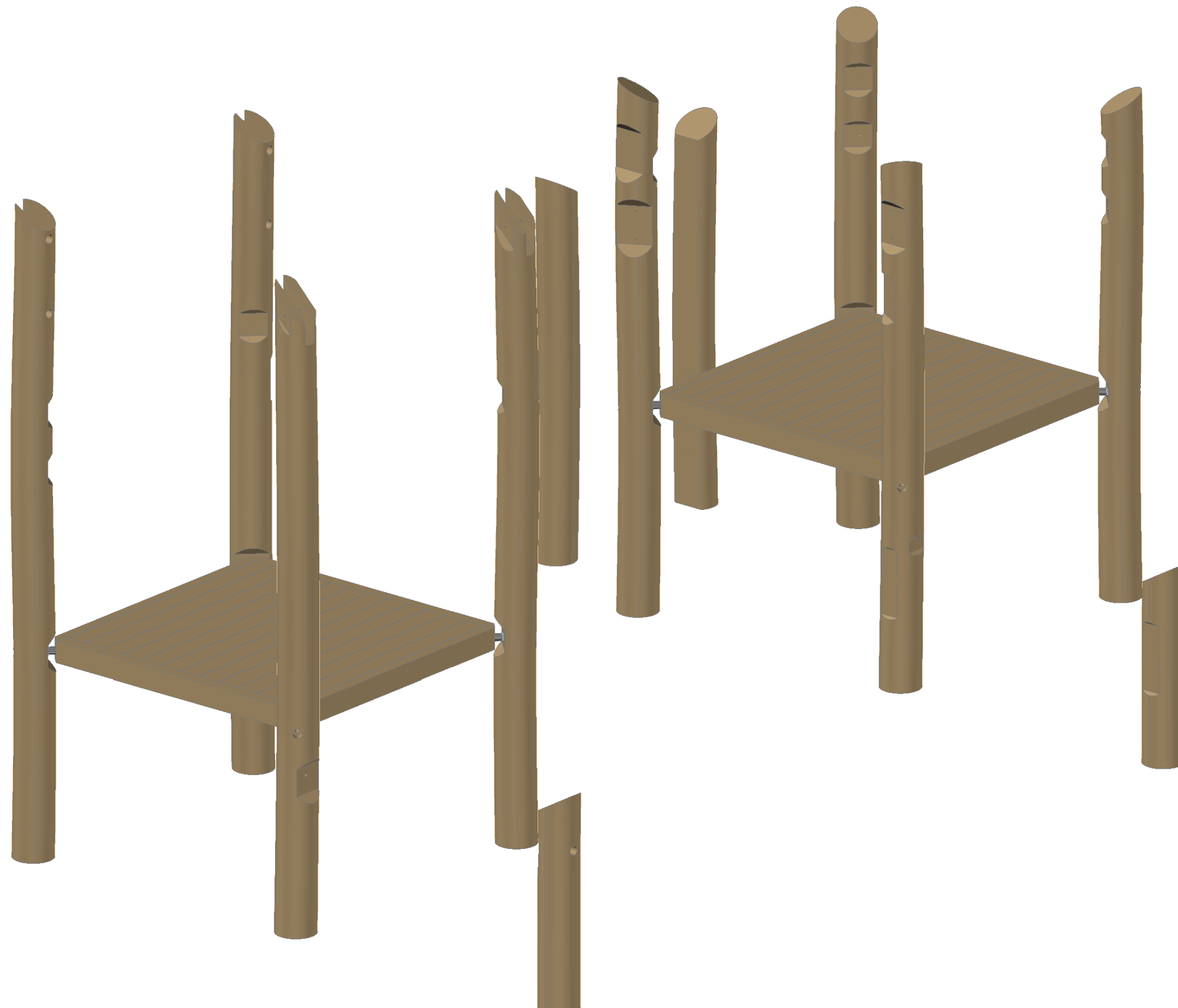
2026-01-21



 2x RO109001-0001

2x TV06B-2000-10027

4x TV01A-2500-10027

2x TV01A-1000-10027

2x TV05A-3000-10027

2x TV04A-3000-10027

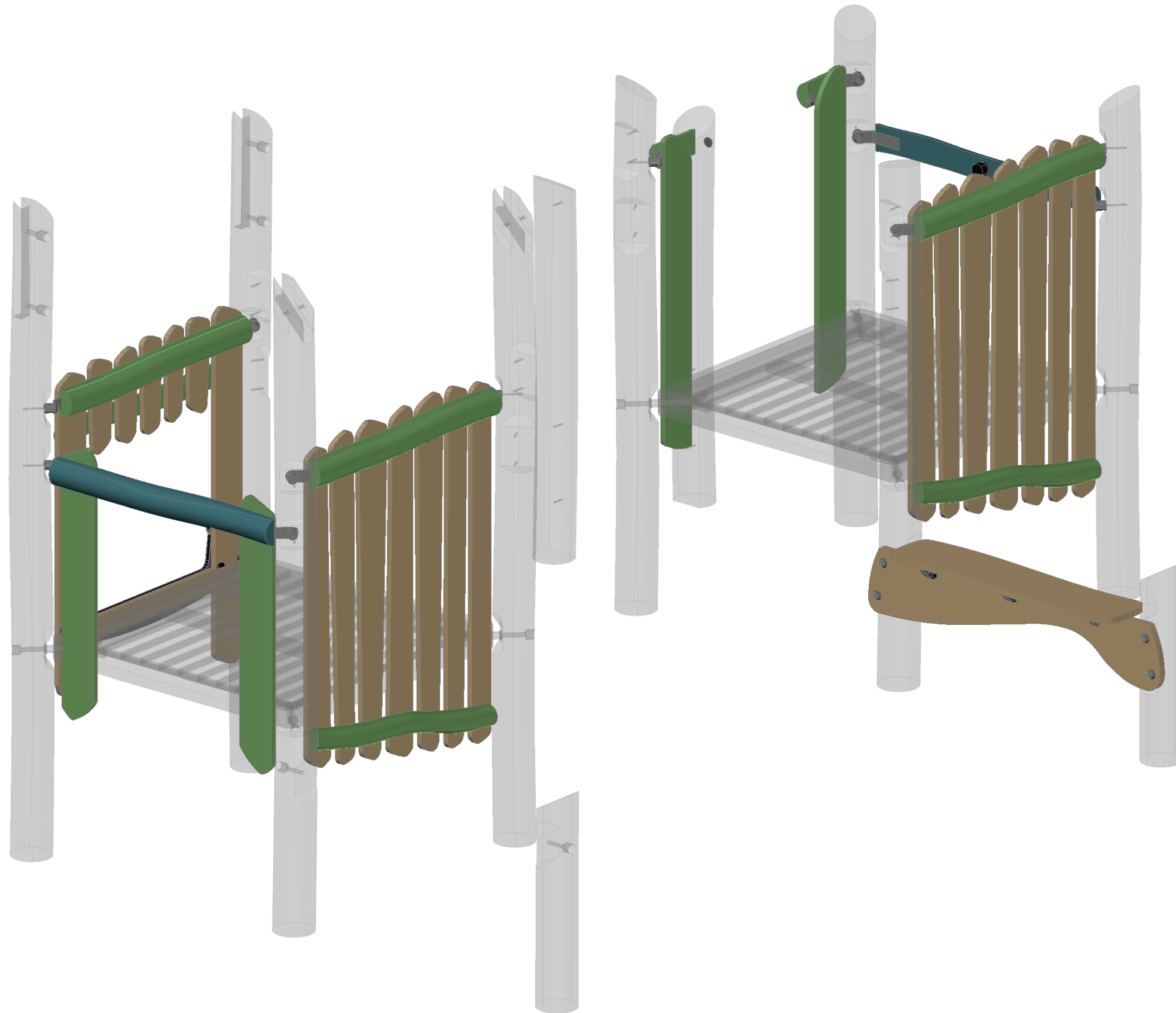

-  1x RO120036-0021
-  2x RO120029-0021
-  1x RO120037-0021
-  1x RO120002-0021
-  1x RO121003-0001
-  1x RO114008-0021

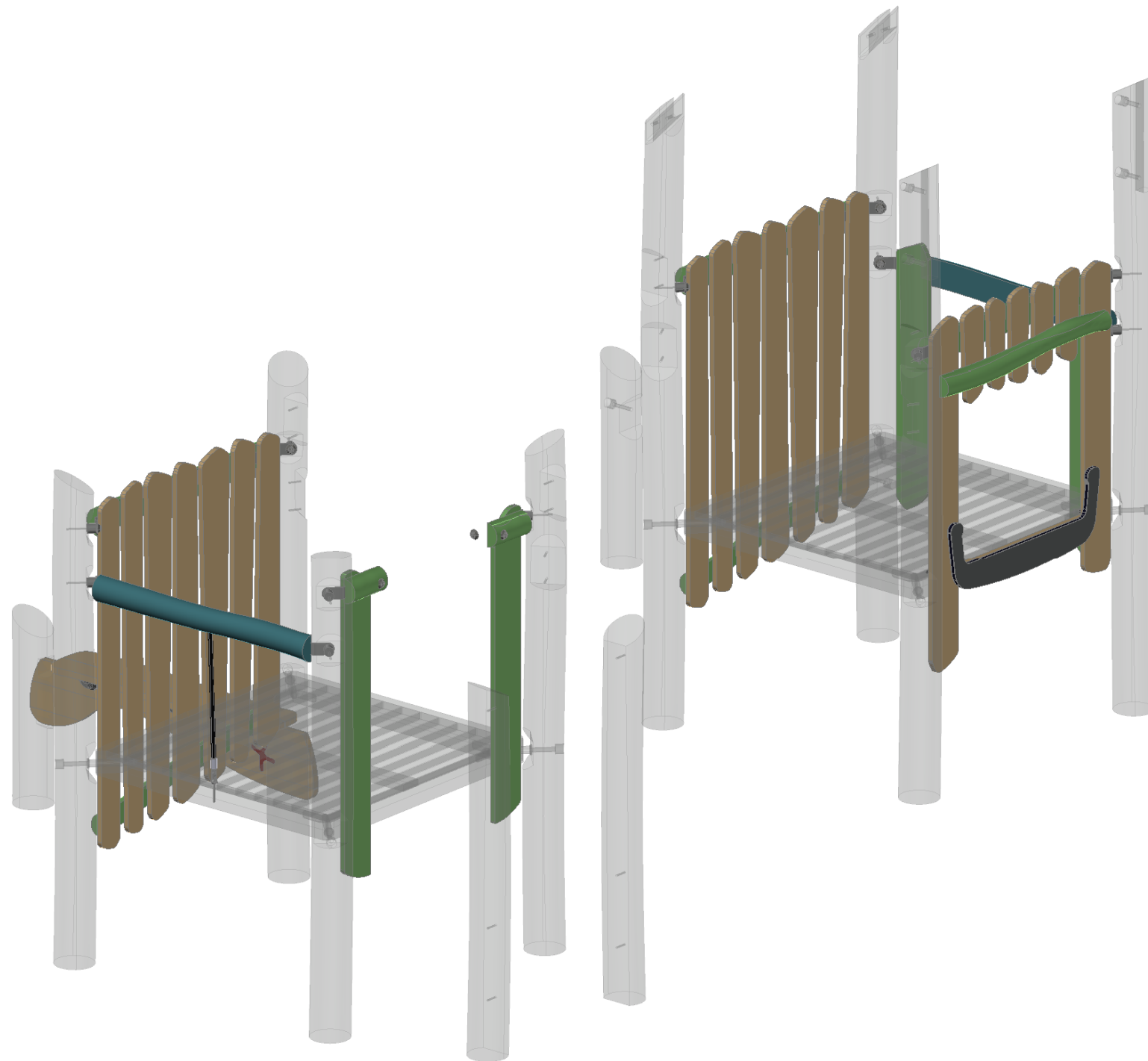



-  1x RO120036-0021
-  2x RO120029-0021
-  1x RO120037-0021
-  1x RO120002-0021
-  1x RO121003-0001
-  1x RO114008-0021

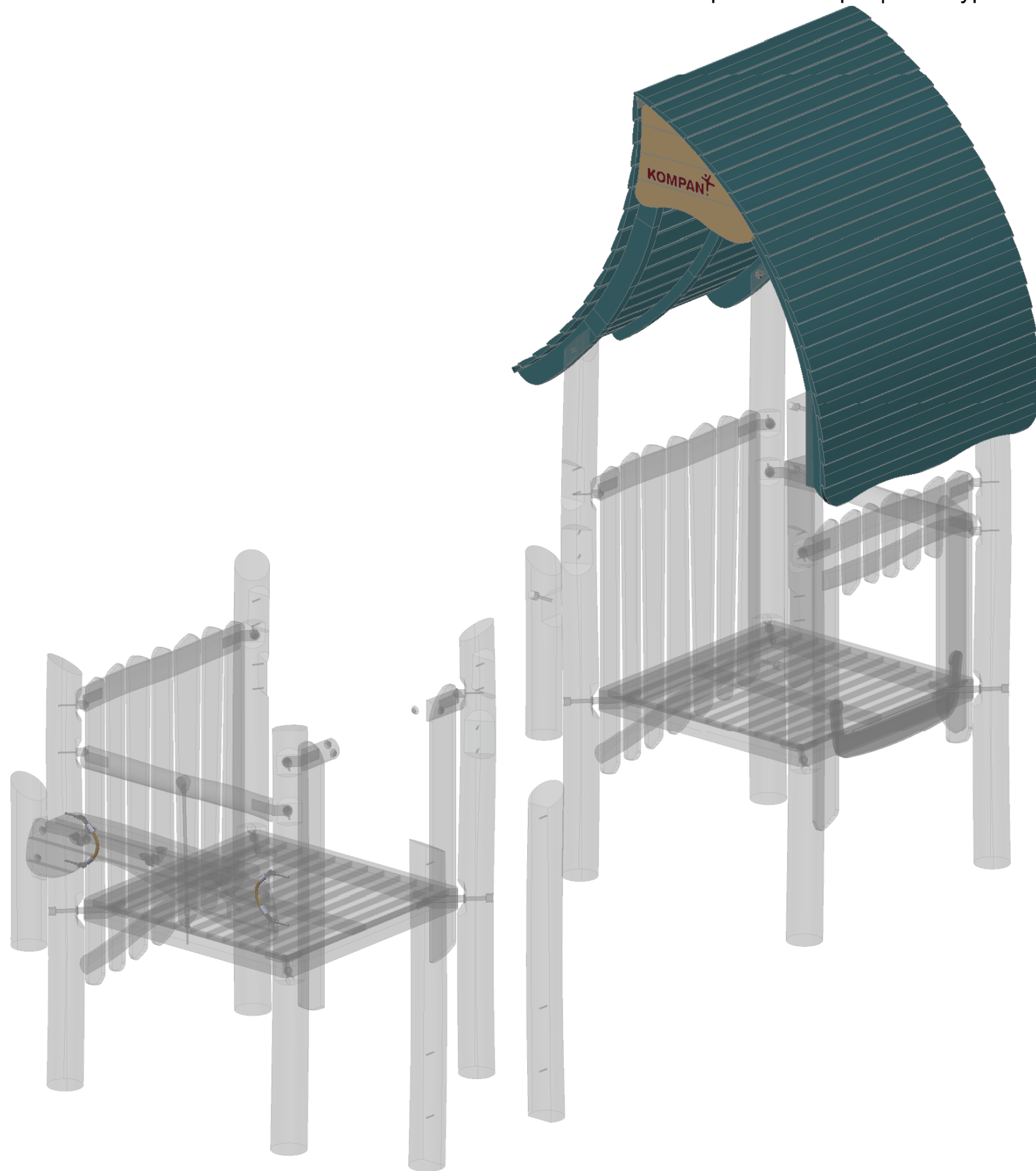

2x RO113066-0001

1x RO108002-0001\_BLUE



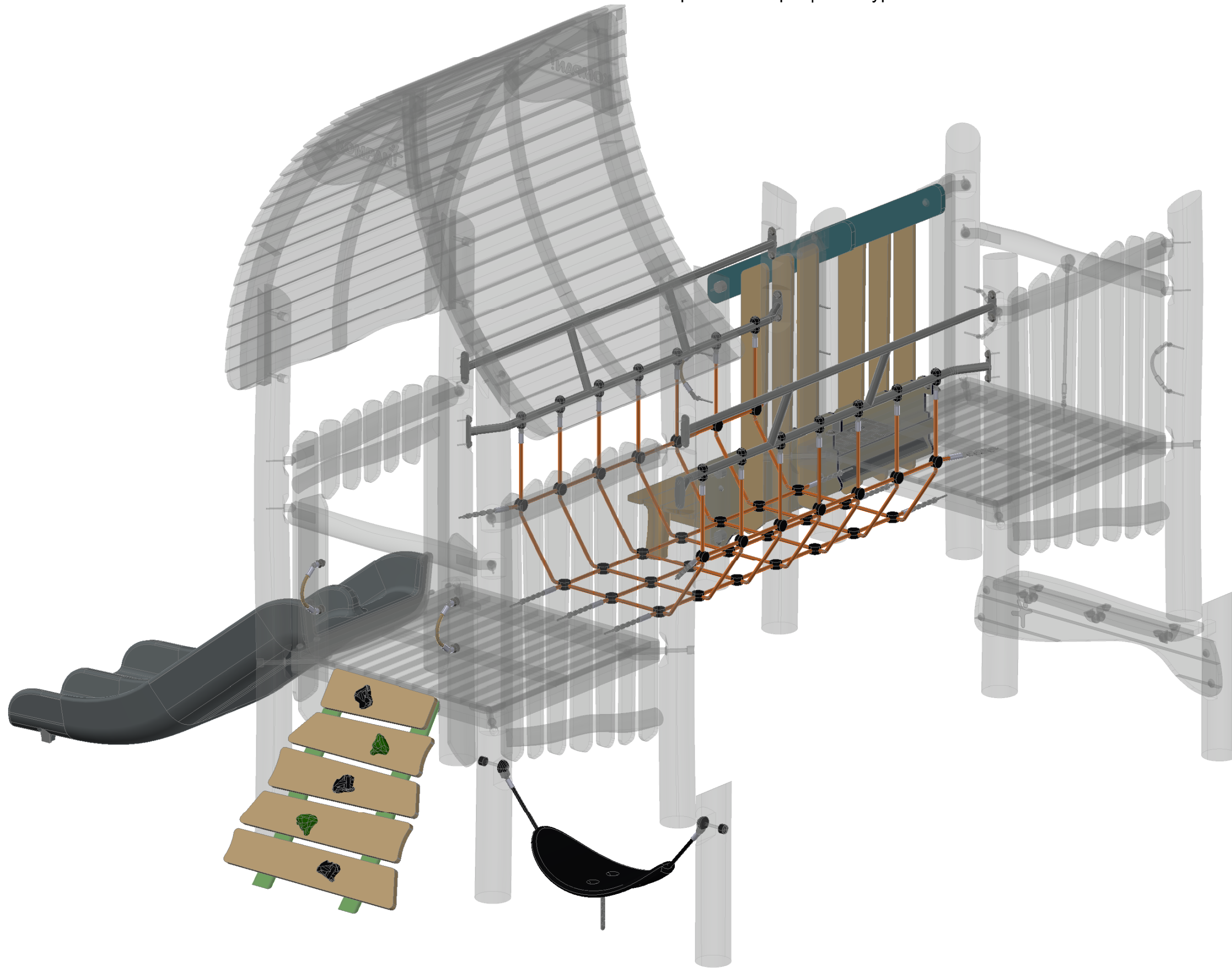

 2x RO113066-0001

1x RO108002-0001\_BLUE



 1x RO128088-0801

 1x RO117088-0621

 1x RO116088-0521

 1x RO113057-0601

1x RO115008-0001\_ORA





NRO-CUSTOM

ID 936417

TomVag

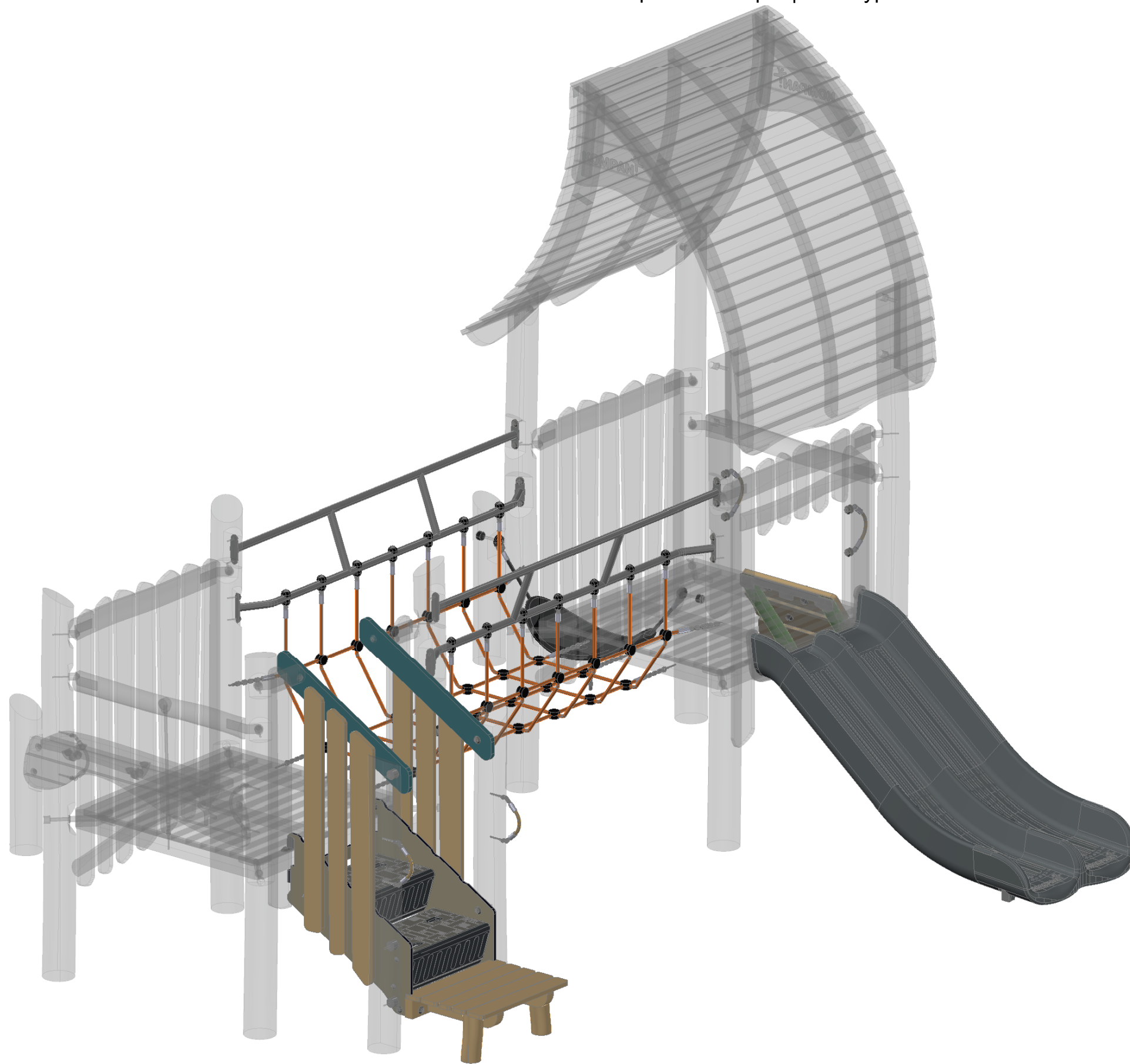
2026-01-21



 1x RO128088-0801

 1x RO117088-0621

 1x RO116088-0521

 1x RO113057-0601

1x RO115008-0001\_ORA